

XII. THE BAKERIAN LECTURE.—*Colour Photometry.*

*By Captain ABNEY, R.E., F.R.S., and Major-General FESTING, R.E.*

Received February 18,—Read March 4, 1886.

[PLATES 24, 25.]

WE think it may possibly be of some interest to the Royal Society if we lay before them the account of the method which we have used, and the results of some experiments which we have made, in measuring the relative illuminating intensities of different parts of the spectrum, as seen by ourselves and by others, and those of different parts of spectra produced under varying circumstances, more particularly as these results have considerable bearing on practical photometry.

§ I. *Formation of a Patch of Monochromatic Light.*

In the *Phil. Mag.* (ser. 5, vol. 20 (1885), p. 172), one of us described a method which he had previously demonstrated to the Physical Society of forming patches of monochromatic light upon a white screen, and alluded to the possibility of adapting it to researches on colour. The method, briefly described, is to pass light through a spectroscope, using a photographic camera in place of the observing telescope, then to isolate different portions of the spectrum and make them fall in a patch on a white screen by means of a lens as shown in fig. 1. Any variations in the apparatus are described further on.

This forms the basis of the method on which we carried on our experiments.

Having paid much attention to the determination of the electrical energy which is required in carbon filaments, and platinum, and other wires, to give a certain total radiation per unit of area, we have endeavoured to extend these researches further by ascertaining not only the energy evolved in the whole visible portion of the spectrum, but also the intensity of radiation in various parts of it.

§ II. *Photometric Methods Used.*

To pursue this investigation it was necessary to elaborate some photometric method which should enable us to compare the visual intensity of one ray with that of another of different colour. Our first idea was to place white paper with black lines closely ruled on it in the colour patches of different parts of the spectrum, and then to ascertain the distance at which the lines would just not be separated by the naked eye. CROVA

(‘Paris, Comptes Rendus,’ vol. 90 (1880), p. 252) has applied this plan to a spectrum photometer, and gave results which do not quite agree with ours. A great many measures of the solar spectrum were made by this plan, but it was felt to be not as uniformly accurate as could be desired, and to be very fatiguing to the observer. In fact, though feasible in making experiments with our own eyes, it was a plan which we could hardly expect others, whose eyes we might wish to test, to try, seeing that their interest in the results might hardly be even personal and not general. One cause of inaccuracy in this method is the liability of the eyes to astigmatism—a difficulty which one of us had to encounter, and found very hard to overcome, the slightest difference in the inclination of the axis of the eyes rendering readings discordant. By this method it would be necessary, therefore, that any casual observer who might be called in should first have undergone an examination for this defect before any idea could be formed of the value of his readings. Another drawback to it is the fact that from the blue to the violet the accommodation of the eyes is insufficient to permit of the lines being seen sharply, the black lines invariably appearing to both of us hazy and covered with a blue mist. This latter difficulty was, however, partially avoided by the use of a small observing telescope, the focus being altered to suit each ray. But the trouble and uncertainty of this plan caused us to seek for some other method which would be more generally useful, and more easily applicable to others as well as to ourselves.

Our next plan was to cut an aperture in a mask of black paper fastened to ground glass, which was made of such a size that the image of it at a fixed distance when thrown on the screen should be of the same size and shape as the coloured patch of light. Behind this ground glass was placed a candle or incandescence lamp, which illuminated it, and thus a patch of yellowish light was thrown on the screen in juxtaposition to the patch whose intensity was to be determined. By moving the light towards or away from the translucent screen the patch of light became brighter or dimmer, and when the two patches appeared of equal luminosity the distance of the candle from the ground glass was noted, the inverse square of this distance being a measure of the brightness of the patch. This method gave fairly concordant results; but it occurred to us that the close juxtaposition of small patches lighted from different sources, as in the RUMFORD system of photometry, would be a more convenient method, and this was accordingly tried.

The light was focussed on the slit, S, of the collimator, C, fig. 1, by a condenser filling the collimating lens, and after passing through two flint prisms, P, of medium density, each of an angle of  $62^\circ$ , fell on the lens, L, of a camera, B, which brought the spectrum to a focus on the ground-glass screen. As before described in the paper quoted, a sliding slit, S', formed in a card, A, was substituted for the dark slide, and the patch of light was formed by being collected by L on a white card, D, placed about 4 feet from the sliding slit. In front of the card was placed an upright rod, E, about half an inch in diameter, to intercept the light from the two sources. A slide, R, carrying

the candle or lamp, T, for the comparison-light, moved on a lath of wood, to which was attached a scale commencing at the screen. When a patch of light of any desired colour was thrown on the white screen the comparison light could be moved along the scale till the luminosities appeared to be equal. Very fair results were obtained by this plan, but the matter of reading was still somewhat difficult until what we have called the "oscillation" plan was hit upon. This plan we will now describe.

Fig. 1.

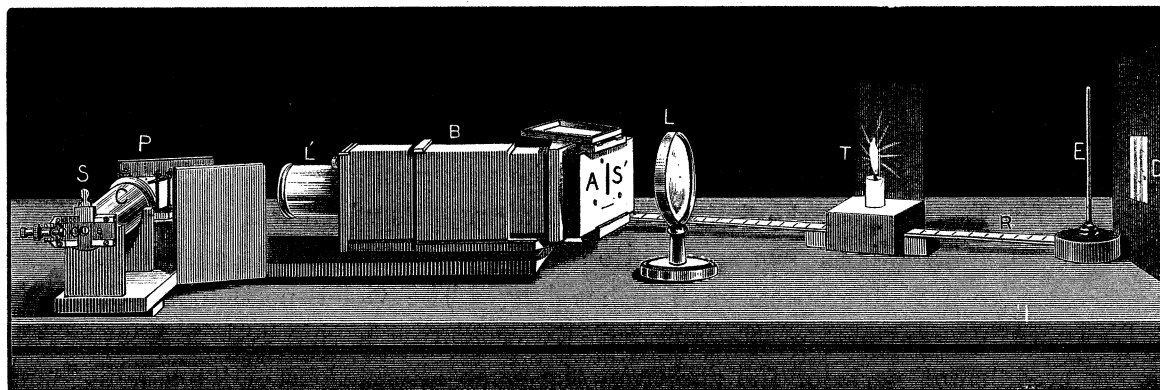

The illuminating value of the spectrum varies greatly in its different parts; the maximum is usually placed in the orange or yellow, and there is a gradation towards each end of the visible spectrum, the rapidity of which varies according to the kind of light used and the part of the spectrum examined. Now suppose we find that with a source of light at 24 inches from the screen it is approximately of the same intensity as the yellow ray of the spectrum, it is manifest that with the source at, say, 30 inches from the screen, its light will be balanced by that of either of two portions of the spectrum, one on the red the other on the blue side of the yellow. To ascertain which those portions are, the slit A is first moved gently from the yellow to the green-blue. When in the yellow the shadow of the rod illuminated by the source of white light will be palpably darker than the other, and when the slit has passed into the green-blue it will be palpably lighter. We find that the best way of determining the intermediate point where the shadows balance is by oscillating the slide gently between points where first one shadow and then the other is palpably too dark; the oscillations become shorter and shorter until the point of balance is determined. The slide is then moved from the yellow through the red and the same process repeated. We thus get the two points in the spectrum whose illumination corresponds to that of the source of light at its then distance from the screen. By successive alterations in the distance of the comparison-light other pairs of points in the spectrum are determined until the limits of the visible spectrum are reached. The curve of intensities of different parts of the spectrum plotted from these observations will be found to be fairly smooth. This curve we call the "luminosity curve."

The most difficult part of the spectrum to measure is close to the maximum, as in this case at each end of the oscillations the shadow illumined by the candle is too light. It is well at this part to oscillate the comparison-light gently backwards and forwards on the scale (the slit slide being stationary) until a balance is obtained, and to compare the result thus obtained with that by oscillating the slit slide.

By commencing with a narrow slit in the collimator the above method answers admirably as far as  $F\frac{3}{4}G$  in the spectrum of a brilliant source of light, and by opening the slit to a moderate degree the intensity of the spectrum as far as  $G$  in the violet can be measured. Beyond  $G$  the method fails to give very reliable results unless the patch of light be diminished very considerably by substituting a lens of short focus for the re-combining lens, and using a much thinner rod to cast the shadows. It will be seen further on that the slope of the curve in the violet is very gentle. It is, therefore, practicable to use for this part of the spectrum a method which is not well adapted for the part near the limit of the red for reasons which will presently appear. The spectrum itself is thrown on a white screen by a lens of long focus—that which we used gave a visible spectrum 8 inches long. The violet portion is sufficiently brilliant to be measured with accuracy. By oscillating a thin rod in front of the screen at different parts of the spectrum the same alternations of “too light” and “too dark” of the candle-illumined shadow are observed, and the part of the spectrum where there is a balance for each position of the candle is determined with very close approximation down to the limit of visibility of the spectrum.

It might be feared that the white light which illuminates the prism might vitiate the results; but this is not so to any measurable extent, as was proved by using a slit and a second prism with which to disperse the white light. This last plan answers, therefore, perfectly for the whole of the spectrum on the green side of the maximum. On the red side the case is different. As a reference to our figures will show, the curve here is very steep, consequently there is a perceptible gradation of luminosity in the length of the spectrum covered by the shadow thrown by the candle, and the comparison is therefore liable to error. By changing the relative positions of the candle, rod, and spectrum, so as to reverse the relative positions of the shadows, we have found that a slightly different value is obtained, but the mean of the two agrees very closely with the value obtained by the other method of comparison.

### § III. *Finding the Position of the Spectrum.*

We fixed our position in the spectrum by means of the bright lines produced by burning different salts in the arc. Those of magnesium and lithium we found most convenient; both of these which we used give copious indications of sodium, and we were thus able to fix the positions on the scale of the red and blue lithium lines, the green magnesium line, and the orange and yellow sodium lines. When necessary, calcium chloride gave us a means of fixing  $H$ . A piece of ground glass being placed

against the slit in the focus of the spectrum, it was easy to see when the position of the slit corresponded with that of any line; the reading of the scale on the slide of course gave the position of the line. The positions of these lines being obtained, wave-lengths for different parts of the spectrum could be interpolated. When sources of light other than the sun or the electric arc had to be employed, a magnesium wire on which a small quantity of chloride of lithium in powder had been placed was burnt in front of the slit. This gave clearly the lines of magnesium, sodium (D), lithium (red), with sometimes a glimpse of the blue lithium line. The position in the blue could be fixed by means of the lines in the base of a candle-flame. But it was rarely necessary to resort to these, since the scale of the spectroscope was sufficiently well known to enable any position to be calculated when one or two lines were fixed.

The following table shows the wave-lengths of the scale used in all subsequent tables :—

TABLE of Wave-lengths.

Scale No.	$\lambda$	Scale No.	$\lambda$
43 =	699	52 =	487
44 =	662	53 =	474
45 =	629	54 =	464
46 =	601	55 =	454
47 =	577	56 =	445
48 =	557	57 =	436
49 =	538	58 =	428
50 =	519	59 =	420
51 =	502	60 =	412

#### § IV. *The Source of Light.*

It is unnecessary to call attention to the great importance of selecting a suitable source of light. For the sake of convenience and comfort the light should be bright, for accuracy of reading it should be steady, for comparison it should be readily obtainable, and at the same time have a constant total illuminating value. The natural inclination is to turn to sunlight for such a source; but it is neither steady from minute to minute, except on rare occasions, nor in this climate of ours readily obtainable. The flame of a candle or of an oil lamp is too feeble, and the same applies to the light from an electrical glow lamp, except under favourable circumstances. Such being the case, we turned to the electric arc light, and found, as we have found in so many of our experiments, the results of which we have had the honour of laying before the Royal Society, that with proper management it gives a steady light and has a constant temperature, as our many measurements of the spectrum illumination showed. We used a hand lamp with inclined carbons (fig. 2), which we had for convenience sake slightly altered from SAUTTER LEMONIER'S pattern. The top carbon, which was the positive pole,

was placed slightly in rear of the bottom carbon, so that the crater, which was used as the source of light, might as nearly as possible face the apparatus. We used the cored carbons, as introduced by SIEMENS BROTHERS for use in their lamps. A Gramme M dynamo which one of us has had in constant use in his laboratory for the last five years, and which is driven by a three-cylinder BROTHERHOOD engine coupled to the axle, supplied the current. This machine has worked without a hitch since it was first set up, and for such work cannot be too highly commended. The current is remarkably constant, its strength being 11 ampères, with an electromotive force of  $42\frac{1}{2}$  volts at the terminals of the lamp, when the armature revolves at 1400 turns a minute.

Fig. 2.

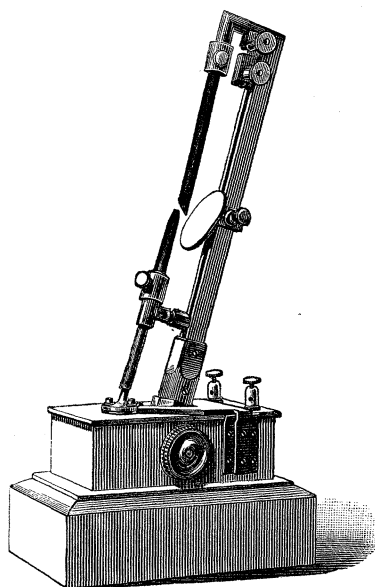

### § V. *The Spectroscopic Apparatus.*

The spectroscopic apparatus has already been described. It may, however, be remarked, that the collimating lens was filled with the light by means of a white flint-glass condenser, which formed the image of the centre of the crater on the slit. Of the parallel rays from the collimator a certain proportion are necessarily reflected from the first surface of the prism. These being received on a screen about three feet distant, and visible to the operator of the lamp, enabled him to see at a glance if the collimator lens was properly filled with light from the crater, and to readjust the lamp when necessary. After having passed through the second prism and the camera lens, the spectrum was accurately focussed on the focussing screen, and a card, as before stated, inserted in the slide grooves. The slit in this card was  $\cdot 05$  inch wide, and on the edge of the card was a scale of 25 divisions to an inch, and read to quarters of a division. [It may be noted that the scale shown in the subsequent pages is converted

into one of a more convenient range for plotting.] The collecting lens was then so placed that the whole spectrum formed a patch about 4 inches square on the screen.

### § VI. *The Receiving Screen.*

In our earlier experiments we used white cardboard as a receiving screen and for ordinary purposes this answered admirably; but the question arose whether card of the same whiteness could under all circumstances be obtained. On consideration we came to the conclusion that zinc oxide could be used with advantage as a standard white. It is to be found in every laboratory, and can be used in distemper. The medium with which we mixed the zinc oxide was a very pure white gelatine dissolved in water, which we used as sparingly as possible. On comparing the illuminating values of different parts of the spectrum on the cardboard with those of a spectrum on a surface coated with zinc oxide, we found a trace of deficiency in the violet, and a smaller one in the green in the former. This was a matter of some concern, as it rendered necessary a repetition with the zinc oxide screen of the series of experiments which we had made with the cardboard. Other white surfaces were tried, but on the whole the zinc oxide answered best.

A card, or board, was brushed over with a cream of the substance, and when dry a second coat was applied and then flatted down with a brush. An ordinary white card placed alongside it appeared yellowish, while the coated card seemed bluish by contrast.

The portion of the screen used for receiving the lights to be compared was limited to a space about 2 inches square by a sheet of black paper, with a hole of that size cut in it placed close in front of and in contact with the screen.

### § VII. *The Comparison-Light.*

In selecting a comparison-light it should be remembered that it has to be moved and is not fixed in position. An electric glow lamp, with a constant current through it, would no doubt be very convenient were it not for the fact that it does not give out light symmetrically in all directions, owing to the different surface of carbon exposed; and the slightest deviation in angular position makes a considerable difference in the illuminating value of such a source at the screen. The flexible connexion necessary for a gas flame is a source of error, as it is liable to get pinched, and the supply of gas to be thus made irregular, and although many readings were taken with a gas flame we found it inferior, with the appliances at our command, to an ordinary candle, or to the SIEMENS'S standard unit lamp burning amyl acetate, which has the value of about .9 of such a candle.

In the experiments recorded in the immediately following pages a candle was used as the comparison light. Burnt as we burnt it, open to the air but not exposed to

draughts, the light emitted was remarkably uniform. The mere fact that we could place curves taken on different days one over the other, and that they should practically coincide, shows that the errors due to variations of the candle must be very slight. With the SIEMENS'S unit lamp similar results were obtained. It may be concluded that the figures given are reliable within a very small percentage. (See Addendum, p. 453.)

§ VIII. *Determination of the Illuminating Value of Different Parts of the Spectrum by the Two Authors.*

When experiments of this nature are undertaken by two people working together, it is clearly necessary that there should be a careful comparison of the effects on their eyes of the same quantity and quality of light. It was a matter of great good fortune that in our case the readings of intensity for each part of the spectrum were identical. As we have not so far found anyone who had a keener perception of the intensity of the whole range of colours than ourselves, we have ventured to call the curve of luminosity, shown in fig. 3, Plate 24, the "normal" curve, as it gives the illuminating value, as determined by us, of the spectrum of the crater of the positive pole. That is to say, the illuminating power of any part of the spectrum is expressed by the ordinate of this curve at the part in question.

We assumed that the light from the arc itself (a part of which must be in front of the crater of the positive pole) would have no appreciable value. That we were justified in our assumption the following experiments will show. With the light we used the strongest part of the spectrum of the arc itself is the green band which commences about "b." If the total intensity of the light of the arc and points together at this part of the spectrum be taken as 100, that due to a whole section of the arc alone is only 42. Now the image of not more than one-half of the total section of the arc is thrown on the slit with that of the crater, we may therefore safely say that the results are affected to a not greater extent than 2 per cent., a quantity inappreciable compared with errors of observation.

In the violet band, which lies about "G" and on the side of "H," the proportion is somewhat larger,—if the intensity of crater and arc be taken at 100, that of arc alone is 25, and not more than half that amount would have to be taken into account; but at this part of the spectrum this difference is practically immeasurable.

It should be noted that the curve which we have given is the mean of a great many, of which none differ 2 per cent. from it and most much less.

To make the diagram more complete we have attached to it the curve of comparative energy as found by the thermopile.



## NORMAL LUMINOSITY CURVE.

Scale reading.	Intensity.	Scale reading.	Intensity.
60·0	·35	48·9	80·0
59·25	·43	48·7	86·5
58·31	·54	48·3	91·0
58·0	·60	47·8	97·0
57·4	·70	47·5	99·0
56·4	1·2 $\frac{1}{4}$	47·1	100·0
56·1	1·3	46·9	100·0
55·8	1·4	46·6	99·0
55·5	1·6	46·2	96·0
55·2	1·9	46·0	94·0
55·0	2·1	45·5	84·5
54·2	3·1	45·4	82·0
53·6	4·2	45·2	74·0
53·0	5·8	45·0	65·0
52·0	9·6	44·9	59·0
51·3	15·4	44·8	53·0
51·0	19·4	44·7	45·0
50·6	26·7	44·4	35·5
50·3	36·5	44·2	23·5
50·0	43·5	44·0	16·5
49·8	52·0	43·7	9·3
49·7	56·0	43·5	5·5
49·5	67·0	43·0	2·5
49·2	73·0	42·4	0

## ENERGY CURVE of visible Prismatic Spectrum.

Scale reading.	Intensity.	Scale reading.	Intensity.
56·85	3 $\frac{1}{2}$	49·20	22
55·90	5	48·25	26
54·95	7 $\frac{1}{2}$	47·30	32
54·00	9	46·35	38
53·05	10	45·40	50
52·10	12 $\frac{1}{2}$	44·45	64
51·15	15 $\frac{1}{2}$	43·50	78
50·20	18	42·55	97

§ IX. *General Remarks on ascertaining the Value of Colour Illumination.*

We may remark that the colour whose illumination we found to be most difficult to estimate is green; as, however, any small difference in the position in the spectrum at this part causes but a very small difference in the intensity of the light, the measurement can be made with great accuracy. Blue-green is more easily compared. We found no difficulty in measuring the red, nor the violet when the brightness is fairly powerful. We have already drawn attention to the difficulty of measuring near the maximum, and have explained how measurements here can be checked.

§ X. *Contrast Colours.*

The change of apparent colour by contrast was remarkably shown in the course of our measurements. It must be recollected that the true colour of the shadow illuminated by the candle is yellowish as compared with daylight. At only one part of the spectrum, viz., near D, does it appear to us of its true colour. The apparent change in colour in passing along the spectrum is very significant. In the red part of the spectrum it assumes a bluish tint, and in the green part a ruddy tint. It must be remembered that the field on which these colours lie is compounded of the light of the candle and of that of the particular part of the spectrum employed.

We have endeavoured to describe, as they appeared to us at different parts of the spectrum, the colours of the two lights :—

	Candlelight.	Spectrum.
At 55 of the spectrum scale	Pale oak stain . . . . .	Deep violet.
53   "   "	Dirty orange . . . . .	Deep cobalt.
52½   "   "	Seville orange . . . . .	Artificial ultramarine.
52   "   "	Indian yellow and salmon mixed	Prussian blue.
50½   "   "	Dark yellow ochre . . . . .	Green-blue.
49½   "   "	Raw sienna . . . . .	Laurel leaf.
49   "   "	Burnt sienna . . . . .	Emerald-green.
46½   "   "	Yellow (of candle flame) . . . .	Yellow (of candle flame).
45   "   "	Grey . . . . .	Scarlet in sunshine.
44½   "   "	Slate grey . . . . .	Cochineal.
44   "   "	PAYNE'S grey . . . . .	Ruby velvet.
43¾   "   "	Slightly blue-grey . . . . .	Cherry-red.
43½   "   "	Blue-grey . . . . .	Morella cherry.
43¼   "   "	Dark blue-grey . . . . .	Dirty red.

§ XI. *Has the Colour of the Comparison-Light any Effect on the Results ?*

This is one of the first questions which presented itself to our minds, and one to which we got a satisfactory answer. A cell containing a solution of fuchsine was placed in front of the comparison-candle, the light of which was thus rendered quite red. Although the individual readings taken under these circumstances differed more from the mean than when the naked candle was used, the general result was the same, as it was when green or blue glass or a blue solution in the cell were used to mitigate the colour of the comparison-light. These measurements alone would be sufficient to arrive at the conclusion that the colour of the comparison-light has no effect on the results ; but an additional proof will be seen further on.

§ XII. *Does the Quantity of Light Admitted to Form the Spectrum Cause a Difference in the Results ?*

This question is one of supreme importance, and we have experimented largely to obtain an answer to it. Observations were made with variations in the width of the opening of the spectroscope slit between  $\frac{1}{1000}$ th and  $\frac{1}{20}$ th of an inch, yet we have

been unable to trace any variation from the curve referred to above. We are aware that statements have been made regarding the luminosity of the red of the spectrum, to the effect that when very dim it loses proportionally more luminosity than do the other colours; but in the experiments which we have carried out we have not detected this difference.

§ XIII. *The Illuminating Values of Colour Mixtures compared with those of their Components.*

It has been assumed, but, as far as we know, never been experimentally proved, that the impression on the eyes of a mixed light is equal to the sum of the impressions of each of the components of the light.

If this law be correct, and our observations did not confirm it, it is evident that our method must be untrustworthy. If, on the other hand, our observations, made under varying circumstances of intensity of illumination, obey this law, then the probability is that our method is sound, and the law correct. To test the illuminating value of colour mixtures, instead of the slide with the single slit, one with three slits, of different widths, any of which could be closed at pleasure, was used, so that three slices of the spectrum could be dealt with simultaneously. The collecting lens being used as before, the light from each slit was thrown on to the same patch on the screen. The illuminating value of each slice was then determined, as well as that of the slices taken in pairs, and of the three together. In these measurements it was necessary to move the comparison-light,\* as the slits must necessarily be stationary, and, as we have stated before, this method is not quite so accurate as the other.

We append some examples. The slide was so placed that one slit occupied a position in the violet, another in the green, and the third in the red. Measures were taken of these colours singly, in pairs, and altogether, and equations obtained by the method of least squares from these six measurements, with the following results:—

	Observed.	Calculated.
R	203	204.25
(R + G)	242	241.75
G	38.5	37.50
(G + V)	45	46.00
V	8.5	8.50
(R + V)	214.0	212.50
(R + G + V)	250.0	250.25

The accuracy of the results may perhaps be best shown by adding the values of the single colours together, and the pairs and single colours, and comparing these values with that obtained by the three colours combined.

\* It will be seen in the addendum that this is now unnecessary if a rotating disc with moving sectors be employed in front of the comparison-light.

$$\begin{aligned}
 R+G+V &= 250 \\
 (R+G)+V &= 250\cdot5 \\
 (R+V)+G &= 252\cdot5 \\
 (G+V)+R &= 248\cdot0 \\
 (R+G+V) &= 250\cdot0 \\
 \text{,,} &= 250\cdot25 \text{ by method of least squares.}
 \end{aligned}$$

A measurement of the red and green was taken on the following day, the position slits in the spectrum not having been altered.

	Observed.	Least squares.
R+G	238	239
G	38	37
R	203	202

The slit of the spectroscope was then opened, and measurements of the same rays made as follows :—

	Observed.	Least squares.
R+G	904	903·3
R	760	760·7
G	142	142·6

It will be observed that in all these cases the relative proportions of red and green are the same within very close limits.

The slit card was then reversed, and the slits placed in other parts of the spectrum. The following results were obtained :—

	Observed.	Least squares.
R	19	19·9
G	130	131·19
V	7·5	7·32
R+G	151·0	150·38
G+V	140·0	138·51
R+V	27·0	26·51
R+G+V	156·0	157·70

Combining the observed results as before we get :—

$$R+G+V=156\cdot7$$

$$(R+G)+V=158\cdot5$$

$$(R+V)+G=157\cdot0$$

$$R+(G+V)=159\cdot0$$

$$(R+G+V)=156$$

The mean of these is  $157\cdot44$ , and by least squares  $(R+G+V)=157\cdot70$ .

Many other equally concordant measurements were made; we therefore feel satisfied that it is true that the impression caused by mixed light is equal to the sum of the impressions of its components, also that the method of measurement adopted is trustworthy. If this be true when the ordinary light of a candle or lamp is used for comparison with different parts of the spectrum, it must be true when using light of any other colour.

#### § XIV. HERING'S *Theory*.

According to HERING, accepting as correct an abstract by Dr. POLE of the various memoirs on the subject ('Nature,' vol. 20, pp. 611, 637, vol. 21, p. 14 (1879)), there are six fundamental sensations of colour arranged in pairs:—black and white, blue and yellow, green and red. The substance which causes the sensations of black and white receives impressions from the whole of the spectrum, being most receptive to the yellow and diminishing in receptivity towards both ends of the spectrum. The blue-yellow substance receives impressions from two parts, one blue and one yellow, of the spectrum, separated by a spot which receives no impression, and where pure green is to be seen. The red-green receives impressions from three parts, one green in the middle and one red at each end, the three parts being separated by two spots which do not affect this substance. Further, HERING supposes that the members of each pair of colours cause what might be called opposite chemical actions, which Dr. POLE has translated as "assimilation" and "dissimilation." When the amount of assimilation in a pair is equal to that of dissimilation no light belonging to the pair is present. As the white-black substance is affected by all the spectrum, he finds that "mixed light appears colourless when it acts on the blue-yellow or red-green substance with equal D (dissimilative) and A (assimilative) power, for then the effects neutralise one another, and the action of the black-white substance alone appears. For this reason two kinds of light which, when mixed, give white are not *complementary* but *antagonistic*; they do not produce white by their combination, but merely destroy each other, and leave visible the white which was already there." As our experiments show that the sum of the intensities of different colours equals that of the mixed light, the statement in the above paragraph would appear to require modification, as it is evident that if one stimulus destroyed the other, the white light resulting from a mixture would be feebler than if the colours were truly complementary. Further, in colour-blind sight there should be perception of light in those parts where it is proved absent.

§ XV. *Testing the Perceptions of Colour in Other People.*

The slit slide was placed in the spectrum focus, and we placed the comparison light ourselves, requesting the observer to oscillate the slide until he obtained a balance. The position of the slit in the spectrum was then noted by one of us by reading the scale at the back of the slide, the observer himself not being able to see the scale. The observation was repeated three times for each position of the candle. We have often found the first two or three measurements to be rather wild, but the observations soon get more accurate. We find it well, as a rule, to place the comparison light so that the first observations shall be a little on the D side of E and then to work up towards the maximum on both sides. By this plan the accuracy of the judgment increases as the maximum is reached. The observer then works back into the violet. This plan ensures a double comparison in the most difficult part of the spectrum, and in case of much difference between the first and second sets of readings a third set is taken; this we have invariably found to agree better with the second than with the first set. It should be recollected that few persons can use an ordinary RUMFORD photometer with much accuracy until they have had some practice with it; it is not therefore surprising that we have found that those who have had some practice in ordinary photometry are, as a rule, much better observers than those who have had no such practice. In some cases we have caused observations to be repeated on two or three separate occasions, and have always found that with untrained eyes the ease and accuracy of observation are much increased in the later trials.

On comparing the "curves of luminosity" plotted from the observations of different persons, we have found some to be identical, or nearly so, with our own; but in some cases, even of persons not actually colour-blind, this is not the case. The variable part may be in the green near the yellow, or in a want of normal perception of red, the appreciation of these colours not being so strong as with us.

*Observer K.*—We append a curve, fig. 4, Plate 24, obtained from a very careful observer whom we will call K.

## K'S CURVE.

This curve is the same as the normal curve, except at the following scale numbers:—

Scale reading.	Intensity.
47·0	100
47·8	87
48·3	80
49·0	68
49·4	60
49·6	54
49·8	47
50·0	42
50·1	40

It will be noticed that whereas in our curve there is a marked convexity about scale number 48·5, with K that part of the curve is much less convex. In his paper (Phil. Trans., vol. 150 (1860) p. 57), Prof. CLERK MAXWELL notices the same thing with regard to one of his observers at another part of the spectrum. It will, however, be seen that in comparing K's curve with ours, the total areas are nearly the same. It would appear that if the trichromatism of the normal eye be an established fact, the slight deficiency in K's curve would be accounted for by a slight want of sensitiveness in the curves which give the sensation of green.

### § XVI.—*Colour-Blindness.*

We are not aware that hitherto any direct and accurate determination has been attempted of the relative luminosities to a colour-blind person of different parts of the spectrum. We have been favoured by several gentlemen who have submitted to an examination of their perceptiveness of different colours. The luminosity curves of the electric arc light as perceived by four of these gentlemen, who are distinctly "colour-blind," were determined in the way above described. While at certain parts their curves fall below ours, their maxima are considerably higher than ours. The reason of this evidently is that their eyes not being equally sensitive to the whole of the spectrum, the light of the comparison-candle is to them depreciated by the proportion of the rays which do not affect their eyes, and their measurements are therefore proportionally exaggerated, this exaggeration being, of course, most evident in the parts of the spectrum to which their eyes are most sensitive. We have plotted each of their curves with the ordinates reduced in such a proportion in each case that no part of the curve lies outside the normal curve. Assuming for the moment that their eyes are not more sensitive than ours for any part of the spectrum, the difference between the curve of any one of them and the normal will show the amount and the position in the spectrum of the deficiency in his colour perception.

*Observer G.*—The first to whom we call attention is G, who kindly put his eyes at our disposal on two occasions for measuring the luminosity of the spectrum. Reducing the ordinates of his original curve by  $\frac{1}{3}$  we obtained a curve which touched our curve, taken under the same circumstances, in the green, but dropped below it considerably in the red, and very slightly in the blue-green. Fig. 5, Plate 24, gives the two curves, the maximum of the normal curve being taken as 100. G's principal defect is evidently in the red; in fact, when he matched the luminosity in the part of the spectrum near C with the candlelight, to our eyes, the shadow illumined by the spectrum was a brilliant red, whilst that illumined by the candle was nearly black. There may be a very slight falling off in the blue-green, which on the trichromatic theory can be accounted for by a slight want of sensitiveness in the "blue-perceiving" nerves. Apparently, also, his perception of violet is not normal,

He describes it as blue, as if the red element which to us is present in violet were unperceived by him.

Having measured and plotted our luminosity curve of the candle, the area of which should represent the strength of the comparison-light as seen by us, we proceeded to derive from it a curve whose area should represent that as seen by him. This we did by reducing the ordinates in the same proportion that those of G's curve mentioned above were less than those of the normal curve. The areas of these two last curves were determined to be in the proportion of 1 : .687. It would thus appear that the measurements made by G would be exaggerated as compared to ours in this proportion; and that, therefore, to compare his original curve with ours his ordinates should be multiplied by .687. The factor which we actually used, as we have said above, was .667, differing only .02 from that obtained by the method described. This may, we think, be looked upon as a fair confirmation of our method of proceeding. Similarly in reducing the curves of R and H we used the factors .465 and .425, and the factor found as above was .455 and .408. For Dr. POLE's curve the factors were respectively .952 and .93.

The bearing of this on practical photometry of unanalysed light is worthy of attention. Colour-blind people can compare two lights of nearly the same tint without apparent error. But when there is any appreciable difference in colour their comparisons will differ from those of people with normal sight.

As an illustration—the ratio of the area of G's reduced electric-light curve to that of the normal curve is .838 : 1, while the ratio of the areas of the candle curve is .687 : 1; in comparing the electric light with that of a candle we should evidently estimate the former light as being  $\frac{838}{687}$ , or 1.22 times stronger than a normal-eyed person would; and this is the proportion of the area of his original curve to that of the normal curve.



## G's observations.

Original readings.		Reduced readings.	
Scale reading.	Intensity.	Scale reading.	Intensity.
43.70	9.0	43.70	1.5
43.80	14.0	43.80	2.3
43.90	18.2	43.90	2.9
44.00	25.0	44.00	4.1
44.48	35.5	44.48	5.8
44.58	61.0	44.58	10.0
44.78	81.0	44.78	13.2
44.88	92.0	44.88	15.0
44.88	111.0	44.88	18.1
45.08	137.0	45.08	22.3
45.18	160.0	45.18	26.2
45.33	190.0	45.33	31.0
45.37	226.0	45.37	36.7
45.57	277.0	45.57	45.2
45.65	309.0	45.67	50.4
45.80	346.0	45.80	57.1
45.98	390.0	45.98	64.0
46.20	444.0	46.20	72.7
46.55	510.0	46.55	83.2
47.73	568.0	47.73	93
48.61	510.0	48.61	83.2
49.20	444.0	49.20	72.7
49.50	390.0	49.50	64.0
49.70	346.0	49.70	57.1
49.89	309.0	49.89	50.4
50.00	277.0	50.00	45.2
50.18	226.0	50.18	36.7
50.47	190.0	50.47	31.0
50.61	160.0	50.61	26.2
50.77	137.0	50.77	22.3
51.07	111.0	51.07	18.1
51.39	92.0	51.39	15.0
51.55	81.0	51.55	13.2
51.85	61.0	51.85	10.0
52.20	35.5	53.20	5.8
54.54	25.0	54.49	4.1
54.54	18.2	54.40	2.9
55.74	14.0	55.57	2.3
56.95	9.0	56.75	1.5

*Dr. Pole.*—In some cases of colour-blindness it does not seem as if there were any diminution in the range of vision along the spectrum as compared to that of normal sight. Such a case we had in Dr. POLE, F.R.S., who has given us permission to mention his name, as he has described in a very interesting paper in the Phil. Trans. (vol. 149 (1859) p. 323), an examination of his own eyes he himself made by another method.

From this paper it appears that with him the sensation of red is altogether absent, but that red appears to him as yellow. He described to us certain shades of orange

as yellow ochre diluted or mixed with white or black. The red about C, and below, appeared to him as yellow mixed with increasing quantities of black. A very interesting feature in his case is that one part of the spectrum which we definitely determined to be at  $\lambda$  5020, scale number 51, is to him absolutely neutral in colour. He describes all tints on one side of this point as being composed of blue, and on the other of yellow, mixed in each case with varying proportions of white or black.

Dr. POLE is a most accurate observer; in very nearly every case did his three observations of intensity come to precisely the same point on the scale. Fig. 6, Plate 24, shows the comparison between his curve and ours. From this it would appear that there is a deficiency both in the red and green. To us his neutral point appeared a cerulean-blue, which to make white requires the addition of a large proportion of yellow.

The colours of the illuminated shadows for different parts of the spectrum he described as follows :—

	Candle.	Spectrum.
At 52 spectrum scale	Yellow.	Blue.
51	Yellowish.	Blue.
50	Certainly yellow, but grey.	Grey, slightly blue.
49	Grey.	Grey.
47	Grey, with a trifle of blue.	Yellowish.
45	PAINE'S grey.	Decided yellow.

It thus appears that at 49, which is  $\lambda$  5386 in the spectrum, the shadows seem of the same tint to Dr. POLE, while to us at that point the candle light appeared burnt sienna, and the spectrum light emerald-green, whilst the colours of the shadows appear to us the same at  $46\frac{1}{2}$  or about D.

## DR. POLE'S observations.

Original readings.		Reduced readings.	
Scale reading.	Intensity.	Scale reading.	Intensity.
55·3	7·0	55·3	2·5
53·5	9·5	53·5	3·4
51·85	17·0	51·85	6·2
51·2	26·0	51·2	9·5
50·7	37·0	50·7	13·5
50·35	55·0	50·35	20·2
50·1	71·0	50·1	26·0
49·8	95·0	49·8	35·0
49·35	122·0	49·35	45·0
49·1	142·0	49·1	52·0
48·8	167·0	48·8	61·0
48·35	199·0	48·35	73·0
47·95	238·0	47·95	87·0
47·5	260·0	47·5	93·0
46·8	277·0	46·8	98·0
46·2	260·0	46·2	93·0
45·85	238·0	45·85	87·0
45·3	199·0	45·3	73·0
45·1	167·0	45·1	61·0
45·0	142·0	45·0	52·0
44·8	122·0	44·8	45·0
44·6	95·0	44·6	35·0
44·45	71·0	44·45	26·0
44·35	55·0	44·35	20·2
44·05	37·0	44·05	13·5
43·9	26·0	43·9	9·5
43·6	17·0	43·6	6·2
43·5	9·5	43·5	3·4
43·35	7·0	43·35	2·5
42·8	0	42·8	0

*Observer R.*—The next colour-blind person whom we examined we will call R. We were very anxious to obtain observations from him, as one of us had seen him some years ago tested by the wool test—an operation, we may remark, which appears to be so unpleasant to the victim, that some persons who had undergone it were deterred by the recollection of it from submitting themselves to our test. We had some slight difficulty in persuading R to do so. Subsequently, however, he remarked that our method was “not unpleasant.”

R's curve and that of H (which we shall presently discuss) seem to us to be typical. It will be seen that with R there is scarcely any perception in the red. At C the luminosity of the spectrum to him is only  $\frac{1}{8}$ th and at D only about  $\frac{2}{3}$ ths of the normal perception. Again he is slightly deficient in perception of the blue rays; but, as will be seen, not so much as is H. Fig. 6, Plate 24, shows his curve compared with the normal. Like G's it had to be reduced in height by using a factor which represents the ratio of the illuminating value of the candle as seen by him to

that as seen by us. When thus reduced his curve touches the normal about E, and after following it a short way leaves it on both sides. On plotting the deficiency curves shown in fig. 6, Plate 24, we found that they both started from E. It was not until after we had done this that we referred to CLERK MAXWELL'S paper, and found that according to him the red curve and the blue curve should meet at E. We may therefore conclude that the observations made by R are trustworthy. It will be noticed that the maximum of the red curve lies about scale-number 45.5, and that his curve ends at 43.6.

## R's observations.

Original readings.		Reduced readings.	
Scale reading.	Intensity.	Scale reading.	Intensity.
56.8	7	56.8	1.5
56.0	7.4	56	1.75
55.4	9.5	55	2.0
54.5	11.5	54	3.0
53.4	19.0	53.5	3.5
52.9	26	53	5.0
52.6	30	52.5	6.75
52.5	38	52.2	8.2
52.2	48.5	51.8	10.0
51.8	55	51.6	11.0
51.6	71	51.4	13.5
50.9	95	51	19
50.6	122	50.8	22
50.38	142	50.6	25
50.25	167	50.4	30
50.1	199	50.25	36
49.8	238	50	44
49.4	290	49.8	52
48.9	325	49.6	59
48.5	346	49.4	63
47.8	367	49	69.5
47.2	346	48.9	71
46.9	325	48.65	74.5
46.7	290	48	79
46.5	233	47.5	77.5
46.3	199	47.2	74
46.15	167	46.9	68
46.1	142	46.6	58
45.9	122	46.5	50
45.8	95	46.3	43
45.6	71	45.8	22
45.4	55	45.5	15
45.3	48.5	45.2	8.5
45.0	30	45	5.5
44.7	26	44	1
44.5	19	43.7	0
44.3	15		
44.1	7		

*Observer H.*—H had no idea that he was deficient in colour perception. He is a gentleman, aged 74, of an acute and educated mind. He attributed his miscalling colours to an ignorance of their names rather than to any deficiency of perception. At first we were not sanguine as to what the results of our tests might be, as we thought he might be right, having sometimes met people whose sole defect is a want of what may be called colour education. Our doubts were however very soon dispelled, and the observations proved to be among the most interesting which we have to record. He had never in his life made a photometrical observation so far as we could learn, so that his test thoroughly tried the practicability of our method as to ease of observation. One of us however moved the slit for him, and asked him to say “too light” or “too dark” as to the shadows, and by gently oscillating the slit we had no difficulty in arriving at his value of the luminosity. Considering his want of practice the readings were very fairly concordant, and can, we believe, be relied on, in which belief we were confirmed by comparing his curve with that of R. It will be seen, fig. 5, Plate 24, that, like R, his red deficiency curve starts from E, and that his luminosity curve ends at 43·6. His blue deficiency is most pronounced. Between C and 43·6 his curve is fuller than R’s, as if his perception to red at that part of the spectrum were greater. But it may be that with the feeble illumination of that part his readings were not so correct, and they were certainly less concordant here than in other parts. We have, however, plotted a curve from the means of the readings, and this makes the maximum of the red deficiency curve rather nearer 46 than 45 on our scale.

We append notes of the colours of different parts of the spectrum as he described them.

46·6 (D)	Yellow or green, more green than yellow.
46	Orange.
44	(1st time) scarlet like sunset. (2nd time after several intermediate colours had been shown) dark green.
54	Blue.
49·6	White, a <i>slight</i> tinge of green.
49	Very light green.

When the two shadows were placed alongside one another as in the photometry he described.

	Candle.	Spectrum.
49	Brown.	Light violet.
49·6	Brown.	Green.
46·2	Dark blue.	Green.

## H's observations.

Original readings.		Reduced readings.	
Scale reading.	Intensity.	Scale reading.	Intensity.
54.32	11.0	43.6	0
53.63	19.0	44.0	1.5
51.47	40.0	44.5	6.0
51.12	43.5	45.0	12.0
50.77	69.0	45.5	20.0
50.60	92.0	45.9	27.0
50.42	119.0	46.1	33.0
50.24	137.0	46.3	45.0
50.05	160.0	46.4	60.0
49.88	190.0	46.5	64.0
49.70	226.0	46.8	70.0
49.70	277.0	47.0	73.5
49.52	309.0	47.5	81.0
49.16	346.0	48.0	84.0
48.64	390.0	48.5	80.0
47.75	417.0	49.0	72.5
47.38	390.0	49.2	69.0
46.85	346.0	49.6	54.0
46.50	309.0	50.0	35.0
46.50	277.0	50.5	19.0
46.33	226.0	51.0	11.0
46.33	190.0	51.5	7.8
46.15	160.0	52.0	5.5
45.61	137.0	53.0	3.5
45.15	119.0	54.0	2.25
45.15	92.0	55.0	1.5
45.07	69.0		
44.72	43.5		
44.53	40.0		
44.35	19.0		
44.0	11.0		

§ XVII. *Summary of Observations on Colour-blindness.*

We have now described in some detail the results obtained from the observations of four persons who are more or less colour-blind. It may be assumed that H and R are totally blind to the red, and the curve of their red deficiency is therefore of more than passing interest, more especially as they so nearly agree in characteristics. An examination of their curves leads us to suspect that the colour entirely wanting in their colour perception is a red which lies about 43.6 on our scale, and would appear to us of a crimson hue. The fact that the red and blue deficiency curves meet at E is also instructive. In G we have an example of partial colour-blindness to red, his curve showing that he is not entirely insensitive to red radiation, but that the perception of it is damped in some peculiar manner. We may mention that some near relatives of his have the same peculiarity of vision.

Dr. POLE'S curve is a most puzzling one, and, as we have already said, it might

appear at first sight that he was blind to red and green, which would correspond to a tetrachromatic theory. On the trichromatic theory also he is not only defective in perception of red, but also of green. Whether this last view is in accordance with his perceptions of colour as he describes them it is difficult to say; but be that as it may, we leave the deficiencies noted for theorists to deal with as they like, merely suggesting that in dealing with Dr. POLE'S curve the others should also be taken into account, more particularly G's, which indicates a deficiency for red intermediate between that of Dr. POLE and those of H and R.

§ XVIII. *Actual Intensity of Illumination seen by Colour-Blind People.*

The question as regards the intensity of illumination actually seen by colour-blind people is one which is very difficult to solve. There appear to us to be two plans by which this might be done, but both are open to doubt. The first is by the method of extinction by means, say, of a graduated wedge. The difficulties in this plan are evident. Our own experience is that the state of health at the time has a marked influence on the precision with which the observations can be made, as has also the time which the observer has spent in complete darkness before the observation. The other method, to which we have already alluded, is that of observing closely ruled lines, and estimating the intensity of the light by the distance at which it had to be placed from the lines in order that they might just not be "resolved."

This latter plan one of us (Captain ABNEY) tried with the observer G. Fine parallel lines, fairly closely ruled on white paper, were placed about 6 feet from an observing telescope, and the two observers, having focussed the lines sharply when they were illuminated by a bright light, alternately observed the disappearance of the lines as a candle was moved from and toward the screen on which the lines were ruled. The following results are the means of several (never less than four) observations in each case, none of which differed more than one inch from the mean.

		Inches.
With the lines vertical. . . .	{ A distance of candle	108
	{ G " "	72
" " horizontal. . . .	{ A " "	64
	{ G " "	71
" " at 45° on each side of the vertical	{ A " "	81
	{ G " "	72

A had previously found his eyes to be astigmatic, and these observations would have proved it if proof were necessary. It appears from the above that except when the lines were horizontal less light was necessary to enable him to resolve them than for G. Apparently the lens of G's eye is spherical, and it is probable that although for one direction of the lines his definition may be inferior to A's, it may be superior for

another direction. Taking the mean of the observations made in the four different directions of the lines, we arrive at the result that the candle value to A : candle value to G :: 75 : 52, that is that G has less perception of light than A.

We have shown that to reduce G's curve so as to lie on ours his ordinates had to be multiplied by  $\cdot 6$ , and that this corresponded to his candle value as derived from  $\frac{\text{area of G's candle curve}}{\text{area of normal curve}}$ . If we multiply 72 by  $\cdot 6$  we get 48 as the relative candle value of G, which differs from that obtained by the above method by 4, *i.e.*, about 8 per cent.

It seems probable, therefore, that the want of appreciation of red in G's case is not made up for by an increased sensitiveness to the other colours. We do not wish to lay too much stress on the above quantitative determinations, but we think that the observations made undeniably show that the actual intensity of the total light of a candle as seen by G is inferior to that as seen by us.

### § XIX. *Curve of Luminosity of the Solar Spectrum.*

As a rule estimations of luminosity have usually been made by comparison with the light of the sun or sky. We, therefore, think it may be of interest to give a general idea of the illuminating value of the different parts of the solar spectrum as determined by us, and we annex two diagrams made by independent methods of observation. The first was our early plan of noting the amount of light required to enable us to distinguish closely-ruled parallel lines. The required amount of light was given by opening or closing the slit of the collimator, the width of opening being measured by a micrometer screw. The lines and observing telescope were fixed, the only variables being the width of opening of the slit and the parts of the spectrum dealt with. This spectrum was taken about 10 A.M. on the 6th July, 1885. The other was obtained on the 17th November of the same year by the method we have described in this paper. We do not lay any particular stress on these curves, as the first was by a method which, as we have said, is particularly difficult to manage, and the latter was taken at a time of year when sunlight is particularly apt to vary. As curves taken on subsequent days agree with this latter, we believe it to be fairly representative of the sunlight as it came to us on that day. The sky was blue, but there was a slight haze which would necessarily alter slightly the proportions of the different parts of the spectrum, particularly the violet and blue, but would not alter the characteristics of the curve in the red, orange, green, and green-blue. This we have been able to determine on several occasions, though from the date given to the present time on no day has the sun been visible long enough to enable us to fully complete a curve. (See Addendum.)

We have put forward these curves to compare with that obtained by VIERORDT (*Annal. Phys. Chem.*, vol. 137 (1869), p. 200), which has, we find, been generally accepted. His method was to take a certain portion of the spectrum, and having extinguished the colour by white light, to calculate the amount of it employed at the



moment of extinction, and thence to deduce the luminosity of the coloured light. This method was used subsequently by Dr. DRAPER.

OBSERVATIONS on Solar Spectrum.

6th July, 1885.		17th November, 1885.	
Scale reading.	Intensity.	Scale reading.	Intensity.
42.2	0	42.54	0
43	6	43.3	4.7
43.6	16	44.3	27
44.6	48	44.55	47
45.5	80	45.17	64
46.8	100	45.80	80
47.7	90	46.55	97.6
48.7	78	47	98.8
49.7	48	47.65	92
50.5	32	48.3	80
51.5	22	48.92	64
53.5	11	49.55	44.5
55.4	6	49.67	42.5
57	4	50.16	30
		50.8	19
		52.05	12.5
		52.2	12
		53.3	8
		54.5	5.5
		55.8	4

Fig. 7, Plate 25, also gives VIERORDT'S results on a bright summer's day; for the sake of comparison we have reduced his maximum to agree with ours.

His table is as follows:—

Position in Spectrum.	Light Intensity.
$a - a\frac{1}{2}B$ . . . . .	80
$B\frac{7}{9}C - C$ . . . . .	493
$C - C\frac{5}{21}D$ . . . . .	1100
$C\frac{9}{21} - C\frac{11}{21}D$ . . . . .	2773
$C\frac{15}{21}D - D$ . . . . .	6985
$D - D\frac{1}{13}E$ . . . . .	7891
$D\frac{1}{13}E - E$ . . . . .	3033
$b - F$ . . . . .	1100
$F - F\frac{1}{4}G$ . . . . .	493
$F\frac{2}{4}G - F\frac{3}{4}G$ . . . . .	90
$G - G\frac{3}{4}H$ . . . . .	35.9
$G\frac{2}{4}H - G\frac{3}{4}H$ . . . . .	13.1
$G\frac{3}{4}H - H$ . . . . .	5.8
Beyond H . . . . .	.9

Now in VIERORDT'S estimation of the intensity of another source of light he has taken the mean of the two positions in the spectrum, and indicated by straight lines joining these points the light intensity of the different parts. We show by a chain dotted line the curve formed in this way. The lines joining the less luminous ends of

those portions of the spectrum on which he operated will, however, be seen by the figure to lie nearer to our curve than the former. But on consideration it would appear as if the curve should be drawn through the more luminous ends of the portions, as these would be the parts of the spectrum where the colour was actually last extinguished by the measured amount of white light. The curve drawn thus differs, as will be seen by reference to the figure, very considerably from ours.

We believe that there are several disadvantages in VIERORDT'S method, and much uncertainty attending its use, at least we have found more uncertainty than in the method of separating lines. We may call attention to the luminosity curve given by Sir W. HERSCHEL in the *Phil. Trans.*, 1801, p. 265, and even allowing for the impurity of the spectrum he worked with, it appears to us that Sir W. HERSCHEL considerably over-estimated the intensity of the blue and violet.

#### § XX. CLERK MAXWELL'S *Diagrams of Colour Intensity*.

If reference be made to CLERK MAXWELL'S paper in the *Phil. Trans.* of 1860, to which we have already alluded, it will be seen that his intensity curves of sunlight are very different in character to ours. There is a dip in the curve at about the position in the spectrum where our curve is most concave, but his curve rises again in the blue, indicating far more intensity than is the case in ours. It is not our purpose now to discuss the cause of this difference, but it should be remarked that his intensity curve was arrived at by mixing light of different colours to compare in whiteness and intensity with the light, the source of which was a white screen illuminated by sunshine.\*

#### § XXI. *Intensity of Light passing through Turbid Media*.

We have thought that in connexion with this curve of luminosity of the light of the sun, as it reaches us after having passed through our atmosphere, it would be interesting to give a comparison of the curve derived from the light of the crater of the electric arc, after it had passed through a turbid medium, with that of the light passing through the same medium but unclouded.

It also occurred to us that the theoretical results obtained by Lord RAYLEIGH regarding the colour of light passed through turbid media, as given in the *Phil. Mag.* (ser. 4, vol. xli. (1871), p. 447), required experimental verification. It is true that in the paper referred to he explains how he attempted to verify his results by comparing sunlight with skylight, and he remarks that "considering the difficulties and uncertainties of the case the two curves" (deduced from theory and experiment respectively)

\* Lord RAYLEIGH has kindly pointed out to us that the scale of ordinates chosen by CLERK MAXWELL for the three colours is purely arbitrary. When his ordinates, at the three points where he supposes pure colour to be exhibited in the spectrum, are reduced to those of one normal curve, the agreement is better.—[July 23.]

“agreed very well.” If a confirmation of the theoretical loss which light undergoes by passing through a turbid medium be obtained by experiment, it is evident that the law of the effect of small particles in scattering light is also confirmed, since the former is deduced from the latter.

According to Lord RAYLEIGH  $I = I_0 e^{-kx\lambda^{-4}}$ , where  $I_0$  is the intensity of the incident light,  $x$  the thickness of the turbid medium, and  $k$  a constant independent of the wavelength which is denoted by  $\lambda$ .  $I$  then represents the intensity of the light which passes through.

To test the matter experimentally, a glass trough was filled with water which was apparently quite clear, and in which the beam from the electric lamp discovered but some few floating motes. This trough was placed between the slit of the spectroscope and the lens used to focus the image of the crater on it, the length of water traversed by the beam being 6 inches (exclusive of the glass walls). The curve of luminosity of the spectrum was then obtained. A solution of mastic varnish in alcohol was prepared, various quantities of which were dropped into the water in the trough for different experiments, the extremely fine precipitate so formed remained in suspension without apparent change for days, the trough remaining in its place throughout. “Curves of luminosity” of the beam through the clear and the turbid water were obtained and plotted on a large scale, and the relative intensities of the beam through the clear and turbid water thus determined. In order to obtain the best results it was found advisable to slightly increase the light admitted to form the spectrum when the water was turbid, on account of the difficulty of measuring a feeble light with accuracy.

The following are the measurements in detail of one pair of curves :—

$\lambda$ .	Scale-reading of spectrum.	Intensity of colour	
		Through the clear water.	Through the turbid water.
	24	·85	2·3
	25	1·4	2·7
	27	2·3	4·0
	30	4·4	6·5
6448	31	5·0	8·0
6374	35	10·0	15·0
	36	11·2	17·0
6210	39	17·0	24·0
	42	22·5	29·7
6061	44	25·5	31·0
	47	27·3	32·0
5900	48·5	28·5	31·5
	52	29·2	29·2
	55	28·5	27·0
5589	59	27	23·5
5459	64·5	24·3	17·5
4602	66·5	22·5	15·6

It will be remembered that more light was admitted to the prisms with the turbid than with the clear water;  $y$  was taken to represent the ratio, and the formula  $I_y = I_0 e^{-x\lambda^4}$  was applied to each of the above results, which gave eight equations containing  $x$  and  $y$ . By the method of least squares two normal equations were formed, from which the values  $x = .146$ ,  $y = 3.72$  were obtained. From independent measurements of the apertures of the slit it was believed that the ratio was 3.8.

The following table gives the ratios of incident and transmitted light as obtained by observation and calculation from Lord RAYLEIGH'S formula.

$\lambda$ .	Observed ratio.	Calculated ratio.
6448	16.0	16.05
6374	15.3	15.4
6218	14.1	14.05
6061	12.2	12.6
5900	11.1	11.2
5589	8.7	8.37
5459	7.2	7.22
5179	5.0	4.90
4602	3.87	3.92

Fig. 8, Plate 25, gives the theoretical curve and the positions of the observed ratios.

On another occasion, with a different degree of turbidity, the values obtained were  $x = .101$ ,  $y = 2.28$ ; from observation  $y = 2.31$ .

$\lambda$ .	Observed ratio.	Calculated ratio.
6448	13.1	12.7
6374	12.1	12.35
6210	11.85	11.60
5900	10.0	9.9
5589	8.25	8.1
5459	7.4	7.3
5180	5.6	5.6
4602	4.8	4.8

Other results of the same character were obtained, but it is unnecessary to give them. The values observed and calculated seem in every case to confirm the theoretical deductions made by Lord RAYLEIGH.

A comparison of the curves, fig. 9, Plate 25, of the absorbed and unabsorbed lights will show the modifications which are effected in the spectrum by passing the beam of light through a turbid medium. That the waves of shorter length are more absorbed than the longer is clear, from the fact that the position of maximum intensity is shifted towards the red end of the spectrum. It will be observed that the clear water and glass ends of the trough even have somewhat affected the spectrum, for there is less convexity in the curve on both sides of the maximum than in the normal

curve of the arc crater, in fact, this former curve more nearly resembles that of sunlight. Now we have already shown in previous papers that the solar spectrum gives evidence of the light having passed through a considerable quantity of water "stuff," and if the sunlight before it reaches our atmosphere has anything in common with the light emitted by the carbon, the modification of the latter in passing through the trough of water would be a further confirmation of our view. We hope to enter into this subject more fully in a subsequent communication, but we may say, in passing, that the observations which we have made of the diminution of the light in different parts of the spectrum, after passing through still greater thicknesses of water, are of great interest, and accord well with the results of corresponding observations made with the thermopile.

§ XXII. *Curves of Luminosity of Carbon at Different Temperatures.*

It was not only a matter of curiosity, but during our investigations it became a matter of necessity, to examine into the illuminating values of incandescence lamps at different temperatures. Although the full results of our experiments in this direction are scarcely germane to this paper, we think it well briefly to notice some of them.

Fig. 10, Plate 25, gives the curve of luminosity of a lamp with a carbon filament in a vacuum of  $\frac{1}{4}$ -millionth of an atmosphere after all gases had been exhausted, both from the filament and from the glass globe enclosing it. A secondary battery supplied the current, and it may be assumed that the temperature remained constant during the whole of each experiment.

Some of the measurements were made by the method of using a patch of monochromatic light, others by that of throwing on the screen the whole spectrum, which measured from A to H 18 inches.

The latter, as already pointed out, is not one which lends itself to accuracy unless precautions are taken; on the other hand, the greater brightness of the spectrum on the screen renders it preferable to the patch method for feeble lights. From a careful comparison of the observations made with the same source of light by the two methods, a constant was determined for converting the results of one method into the terms of the other.

During these experiments no part of the apparatus was even touched; everything remained unchanged, except the amount of current, and therefore the temperature of the filament. With the current of approximately  $2\frac{1}{4}$  ampères from 26 boxes of a secondary battery, and an E.M.F. of about  $49\frac{1}{2}$  volts, the filament was of a fairly bright orange colour, and its curve of luminosity is given as C, fig. 10, Plate 25. Curve B represents the result of passing the current from 28 boxes through the lamp. They gave a current of  $2\frac{2}{3}$  ampères and an E.M.F. of 53 volts; curve A, that from 34 boxes, which approximately gave  $3\frac{1}{4}$  ampères and  $64\frac{1}{2}$  volts.

The light represented by curve B appeared to the naked eye a very bright orange, and would certainly be estimated to be as white as gaslight; the lamp would be

intended by the makers to be worked at about this intensity. The light represented by curve A was brilliant, and would certainly be supposed to be whiter than that of gas burnt in a good fishtail burner. On plotting curve D, however, which is that of gas burnt in a fishtail burner, an image of the flame having been thrown on the slit, we were somewhat astonished to find that it indicated a whiter light than our incandescence lamp would give with 34 boxes. On comparing the shadows of the two lights in an ordinary RUMFORD photometer, we found a confirmation of the truth of our curves, for the shadow illumined by the gas was distinctly blue-grey as compared to the yellow shadow illumined by the lamp. Our unaided eyes, therefore, had failed to appreciate the colour of the light. We found that with 34 boxes of the secondary battery the lamp gave a light of almost precisely the same colour as that of the candles which we used in our measurements.

We next determined the luminosity-curve of a candle, and found that it lay very closely on that of the lamp with 34 boxes. There was, however, a slightly larger amount of blue-green in the former than in the latter, which is a point of some interest.

Reverting to the curves of the incandescence lamps, it will be remarked that at comparatively low temperatures there is marked deficiency in the yellow-green of the spectrum about  $\lambda$  5630, as shown by a decided bend in the curve, which, however, diminishes with increase of temperature, and in curve C is scarcely discernible, showing that the emissivity of carbon for that part of the spectrum increases proportionally more than for the adjacent parts. It would appear, then, that cold carbon should probably be less absorbent of these rays than of others, a point which we have not determined as yet. The scale of A must be multiplied 6.67 times, and that of B 1.8 times to arrive at the actually observed values compared with C.

#### LUMINOSITY of Incandescence Light and Spectra.

Intensity.	26 boxes. Scale reading. C	28 boxes. Scale reading. B	34 boxes. Scale reading. A	Gas. Scale reading. D	Intensity.	26 boxes. Scale reading. C	28 boxes. Scale reading. B	34 boxes. Scale reading. A	Gas. Scale reading. D
100	46.2	46.25	46.3	46.35	100	46.2	46.25	46.3	46.35
96	46.45	46.45	46.5	46.75	96	45.65	45.65	45.8	46.00
90	46.72	46.75	46.83	47.28	90	45.35	45.35	45.55	45.65
80	46.92	47.08	47.3	47.9	80	45.05	45.05	45.10	45.25
70	47.10	47.35	47.70	48.4	70	44.88	44.85	44.9	45.00
60	47.28	47.50	48.10	48.75	60	44.7	44.7	44.7	44.85
52	47.50	47.72	48.50	49.00					
50	47.60	47.85	48.60	49.05	50	44.60	44.6	44.6	44.78
46	47.80	48.10	48.75	49.15					
40	48.20	48.50	49.00	49.4	40	44.45	44.45	44.45	44.60
30	48.90	49.20	49.50	49.90	30	44.25	44.25	44.28	44.35
20	49.70	50.00	50.20	50.5	20	44.00	44.00	44.00	44.10
15	50.10	50.45	50.65	50.95					
10	50.80	51.00	51.30	51.60	10	43.6	43.6	43.6	43.6
6	51.5	51.8	52.2	52.6	6	43.4	43.4	43.4	43.4
4	52.00	52.5	53.2	54.00	4	43.2	43.2	43.2	43.2

§ XXIII. *Unit Surface Values of Illumination.*

As a matter of curiosity we have made a comparison between the illuminating values per unit of surface of the filament of the incandescence lamp with the current from 28 boxes and of the crater of the arc light.

This was done in the following manner: by means of a lens of about 9 inches focal length, the image of the crater was accurately focussed on a slit of moderate dimensions, which it well filled. The diverging beam of light from the slit was made to fall on a white screen, and its illuminating power compared with that of a candle by the RUMFORD method. The relative distances of all parts of the apparatus was carefully measured, that of the screen from the slit being in this case 498 inches, and of the lens to the slit 89·5. The mean distance of the candle was 38 inches from the screen.

The positions of the lens and slit being unchanged, the incandescence lamp was substituted for the arc, and the image of the filament was made to fall on the slit, which it more than filled. The screen was then placed at 93·5 inches from the slit, and the light compared as before with that of the same candle, which had to be placed at 157 inches from the screen. Combining these two measurements it was found that, area for area, the light of the crater was 484 times that of the filament in the incandescence lamp. We have found this to be a convenient plan of measuring the illuminating values of areas, and one of us extensively practised this method in a long series of experiments undertaken for the War Department at Chatham six years ago.

## POSTSCRIPT.

(Added March 4, 1886.)

§ XXIV. *Practical Application of the Mode of Testing.*

As an example of the practical method of testing luminosity by rapid alternations of "too light and too dark," we would call attention to the method that can be adopted in evaluating the light from a candle and a glow-lamp. Suppose we wish to know the current, &c., which in a given glow-lamp will produce say 16 candles, a candle is placed say 3 feet and the glow-lamp 12 feet from the screen, before which a rod is placed. A current is passed through a glow-lamp and some carbon pellet resistances,\* which can be screwed together more or less tightly. The resistance is increased or reduced as may be found necessary till it gives an equal illumination to the screen that the candle does. The pellet resistances are then tightened and slackened alter-

\* Since the above experiments were made we have substituted for the pellet resistances carbonized cloth resistance, which was kindly supplied by MESSRS. VARLEY of Mildmay Park. The change of resistance in the circuit which this can effect by screwing up is sufficient to allow an ordinary incandescence lamp of 100 ohms resistance to vary between a black heat and a full white heat.—[July 23.]

nately so as to make the illuminated shadows on one side too light and too dark. With rapid alternations the point of what we may call equilibrium is found, and the current read off by suitable means. The same method of procedure may be carried out to compare any light with an incandescence light, and the results show great concordance one with the other.

#### ADDENDUM.

(Added June 9, 1886.)

#### § XXV. *Elimination of the Variations in the Comparison-Candle.*

Since our last communication was made on this subject, we have introduced some improvements into our mode of using the instrument described therein, which we think will meet any objections which may be made to our use of a candle or other similar source of light in the comparison-light. Mr. VERNON HARCOURT, F.R.S., whose colour perceptions we tried, found that the brand of candle we employed burnt more uniformly than the standard candle, and he gave us the results of some careful measurements which he made. Except for the first five minutes, when the candle he tested evidently was not in its normal condition, and readings with which we should have rejected, the light varied but slightly; and we have no doubt that the results we have already given are very nearly correct, particularly as we find our curves agree almost absolutely with those taken by our improved methods which we describe below. It may be remarked that fluctuations in the candle light are readily distinguished in plotting the curves, since observations are taken on each side of the maximum; and it is readily seen that if the pair of observations are too high or too low the candle has varied. Their variations disappear when the readings for a curve are taken in three sets. To meet, however, the possible objection that may be taken to the candle method, we have employed an incandescence lamp giving about 10 candles, and instead of shifting this comparison-light have kept it stationary, and altered the intensity of its light falling on the screen, by means of rotating discs in which are movable sectors to cut off more or less light. These discs are set to give various apertures, and the reading taken as before. We drive the discs by means of a small electromotor, which causes them to rotate about 40 times a second. We are glad to state that the results for the electric light do not vary from those originally obtained.

#### § XXVI. *Measurement of Sunlight.*

Owing to the variability of sunlight during a set of experiments to determine the luminosity of its spectrum, we considered that it would be advisable to make the comparison-light vary in the same degree as the light which formed the spectrum.



To effect this we made the light which had passed through the slit and the collimator to be our comparison-light by using the reflection from the first surface of the first prism.

The general arrangement of the apparatus is seen in the accompanying diagram.

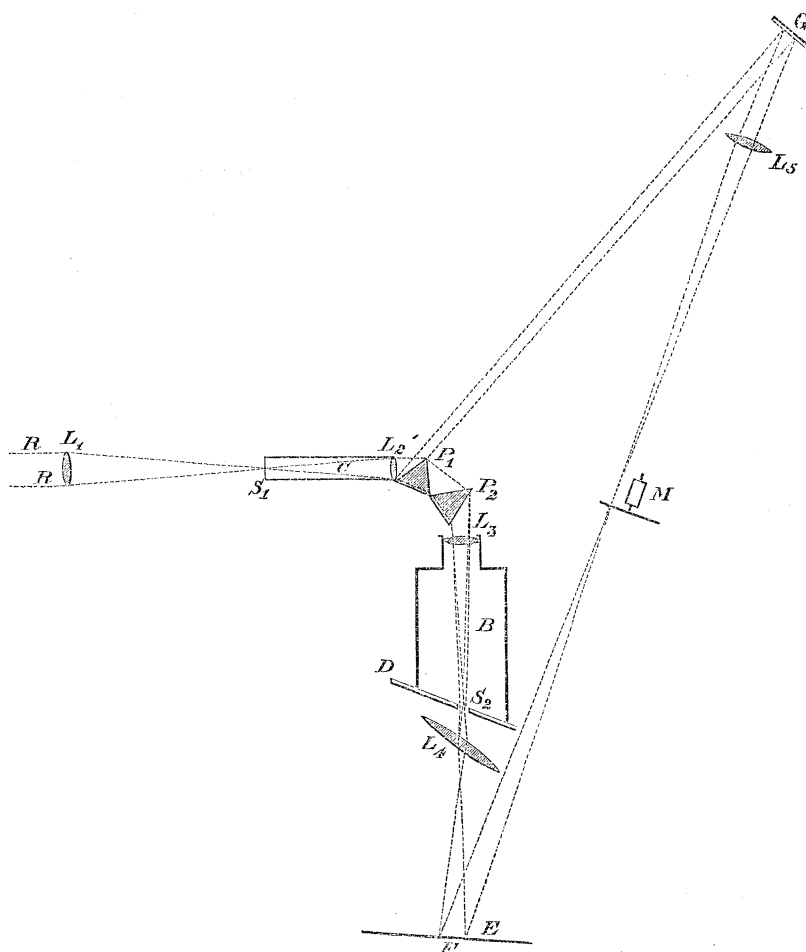

RR are rays coming from a heliostat, and a solar image is formed by a lens  $L_1$ , on the slit  $S_1$  of the collimator C. The parallel rays produced by the lens  $L_2$  are partially refracted and partially reflected. The former pass through the prisms  $P_1P_2$ , and are focussed to form a spectrum by a lens  $L_3$  on D, a movable screen in which is a slit,  $S_2$ . The rays coming through  $S_2$  are collected by a lens  $L_4$  to form a monochromatic image of the near surface of the second prism on F. When D is removed the image of the surface of the prism is white, obtained by tilting the lens  $L_4$  at an angle as shown.

The reflected rays from  $P_1$  fall on G a silver-on-glass mirror. They are collected by  $L_5$ , and form a white image of the prism also at F.

At M is a small electromotor carrying moving sectors as already described.

It will be seen that both the comparison-light and the spectrum itself are formed by the light coming through the slit. Any small haze passing over the sun thus

affect both alike, and comparisons are easily made. Of course for the electric light the same procedure may be had recourse to, and gives the same curve as when the candle is used as the comparison-light.

TABLE of the luminosity of the solar spectrum taken by new method.

No. I.—4th June, 1886, 2 P.M.			* No. II.—21st July, 1886, 2 P.M.		
Luminosity.		Scale readings.	Luminosity.		Scale readings.
Comparative apertures of rotating disc.	Reduced Intensity.		Comparative apertures of the rotating disc.	Reduced Intensity.	
°			°		
105	100	47.33	135	97.8	47.24 and 46.77
100	95.2	47.73 and 46.54	120	87.0	48.16 ,, 45.97
90	87.5	48.52 ,, 45.75	105	76.1	48.61 ,, 45.63
80	76.2	49.01 ,, 45.35	97	70.3	48.84 ,, 45.52
70	66.6	49.41 ,, 45.15	90	65.2	49.18 ,, 45.40
60	57.1	49.91 ,, 44.96	80	58.0	49.64 ,, 45.17
50	47.6	50.20 ,, 44.70	70	50.8	49.87 ,, 45.06
45	42.8	50.40 ,, 44.66	60	43.5	50.09 ,, 44.83
40	38.1	50.60 ,, 44.56	50	36.3	50.53 ,, 44.60
35	33.3	50.80 ,, 44.46	40	29.0	50.76 ,, 44.49
30	28.5	50.90 ,, 44.42	30	21.7	51.10 ,, 44.38
25	23.8	51.09 ,, 44.36	20	14.5	51.56 ,, 44.26
20	19.0	51.39 ,, 44.26	15	10.8	51.90 ,, 44.03
15	14.2	51.69 ,, 44.16	10	7.25	52.92 ,, 43.80
10	9.5	52.28 ,, 44.07	5	3.62	53.84 ,, 43.58
5	4.8	53.27 ,, 43.87	3	2.17	54.75 ,, 43.35
2.5	2.4	54.46 ,, 43.47	2	1.45	55.89 ,, 43.01
1.6	1.6	55.65 ,, 43.37	1	.72	57.94 ,, 42.67
.8	.8	57.23 ,, 43.17	.330	.24	61.59 ,, 42.21
.4	.4	59.21 ,, 43.00			

Fig. 11 gives the curves drawn from the above tables.

It should be remarked that from the measurements we have made in London, the solar curve varies considerably according to the direction of the wind. A wind from the east diminishes the intensity of the blue end of the spectrum—a fact no doubt due to the smoke haze which is then prevalent.

We omitted in our paper to point out the method by which the prismatic spectrum curve can be converted into the normal spectrum curve. It will be seen that a very approximate curve can be obtained by using  $\frac{dI}{\lambda^2}$  or  $\frac{1}{\lambda^3}$  as the factor by which the ordinates of the curves in the former can be reduced to the latter.

\* This table gives a fair idea of the luminosity of the solar spectrum in July of this year, the wind being in the S.W., and the sky blue. It agrees with other curves taken on different days, and is a representative one.—[July 23.]

Fig. 3.

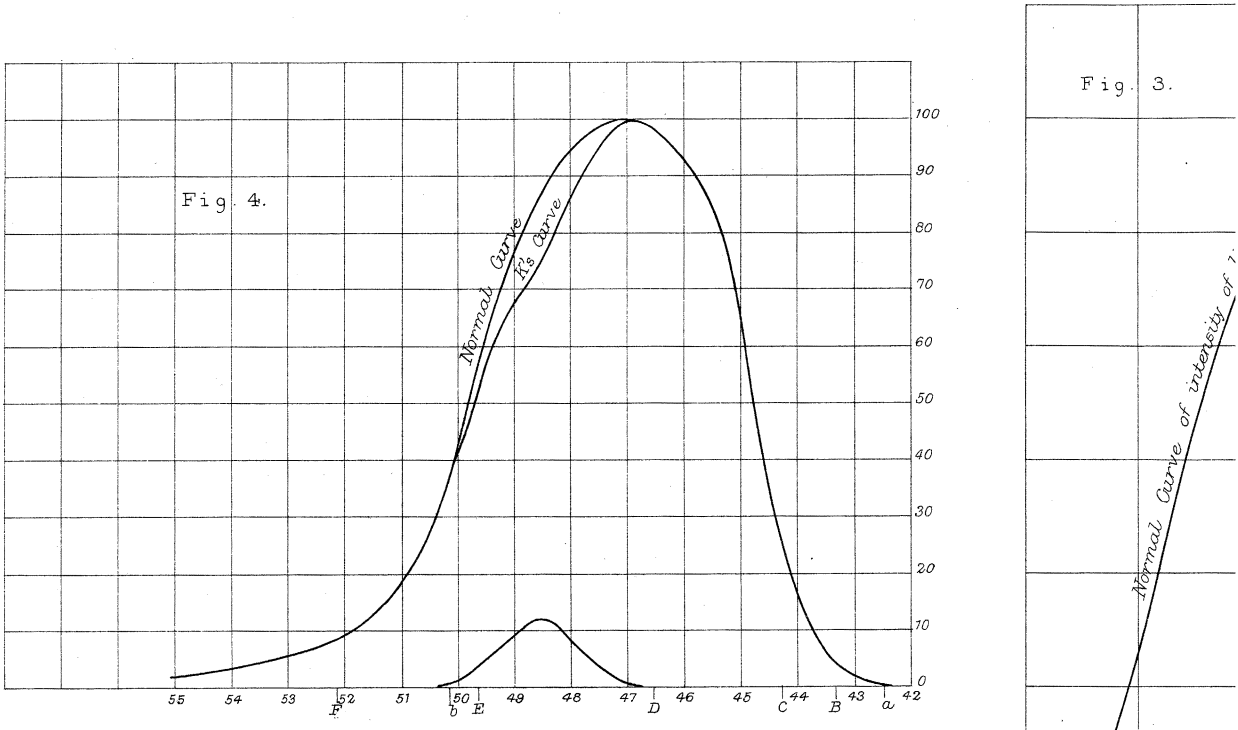

Fig. 4.

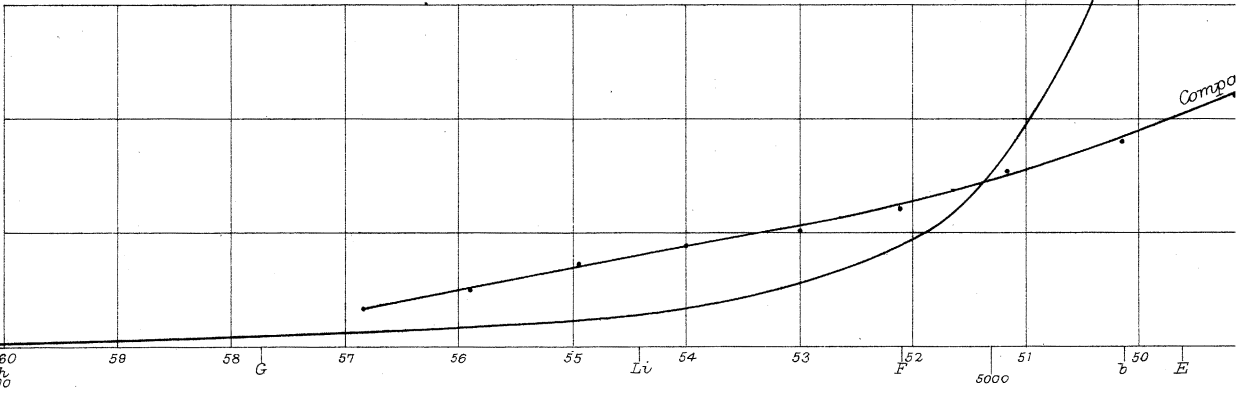
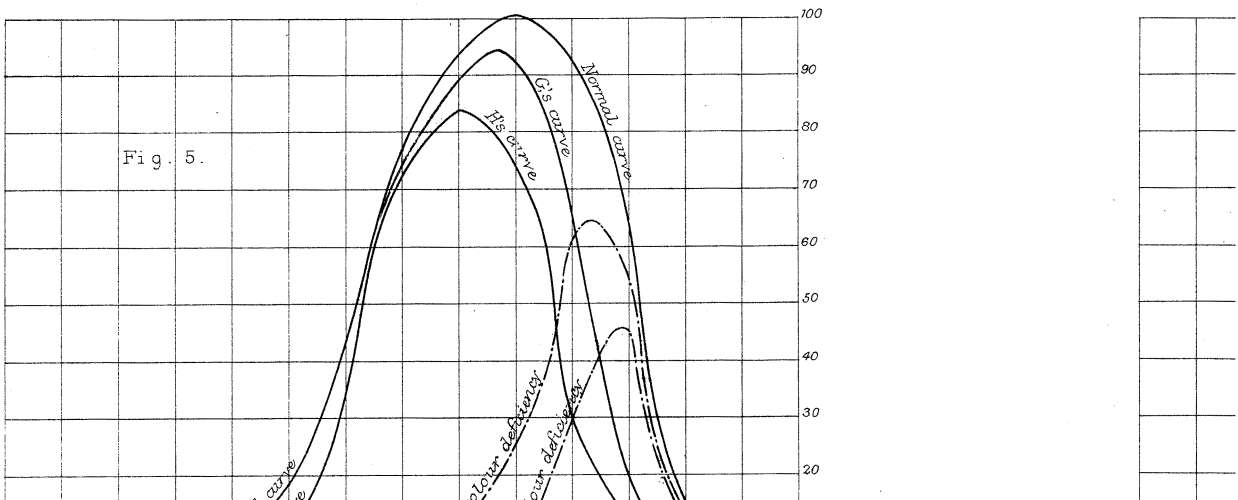
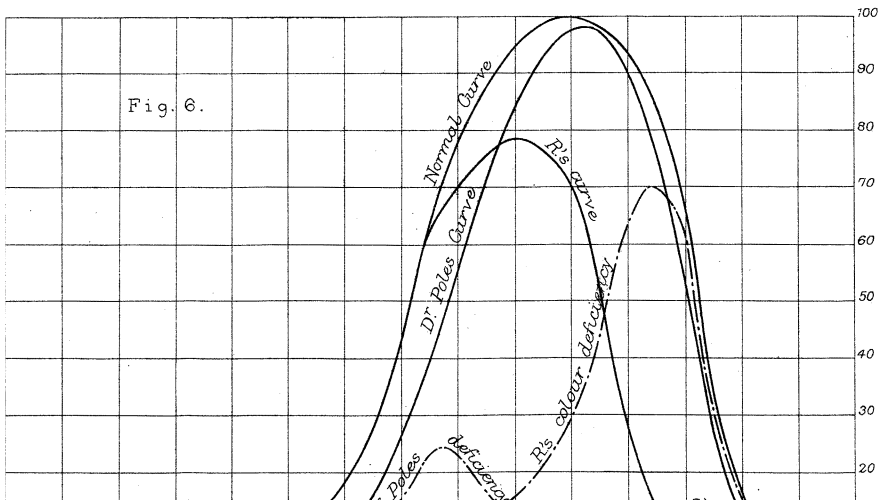
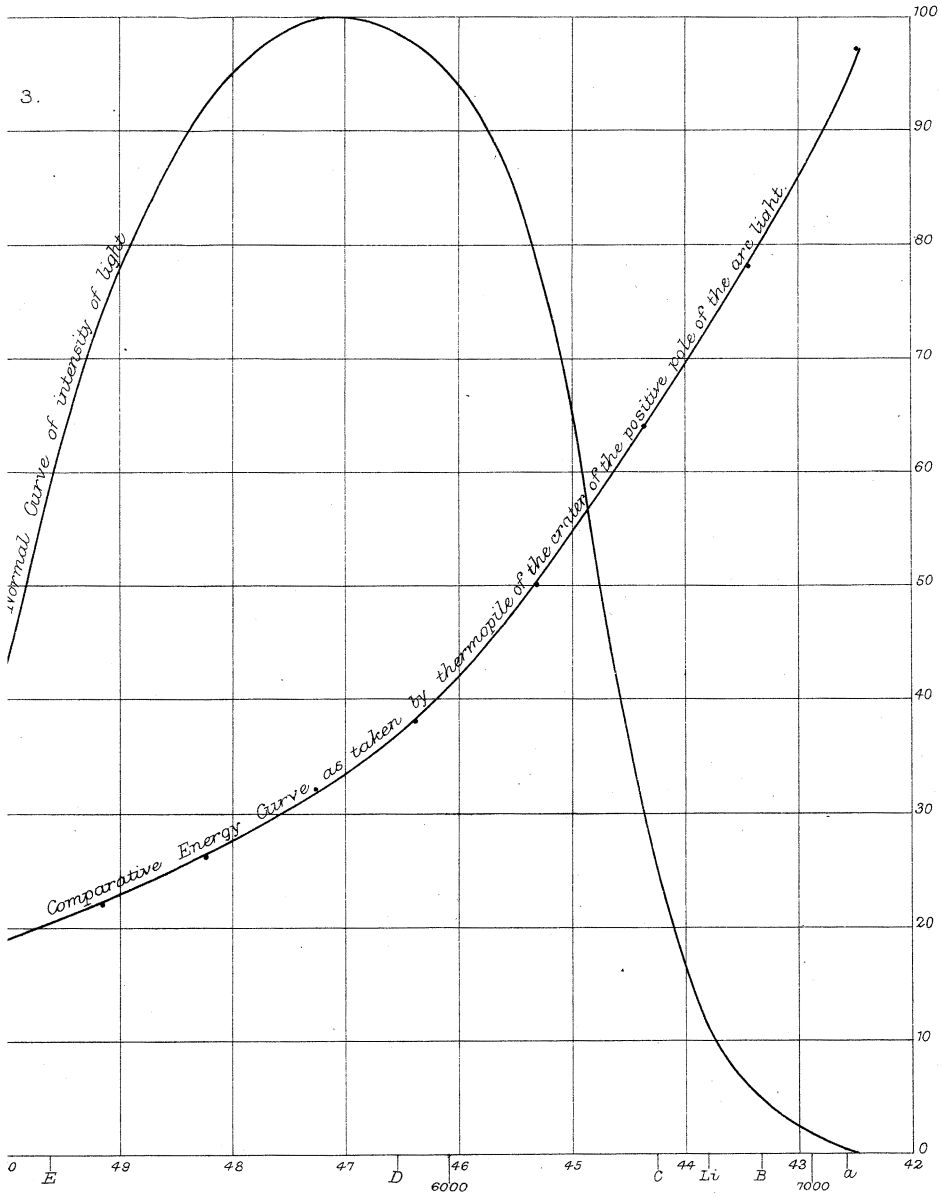
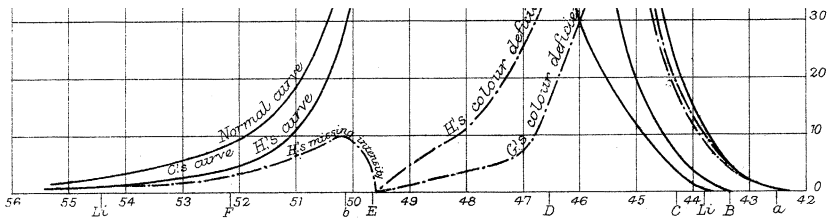

Fig. 5.



WL 4000





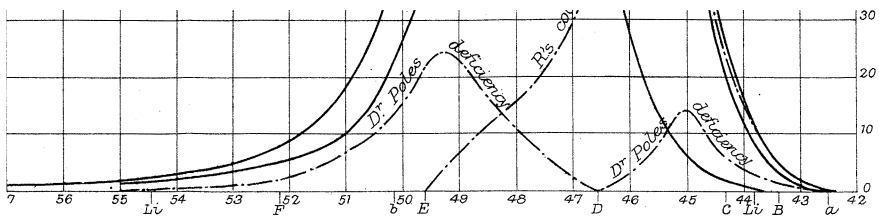

West, Newman & Co. lith.

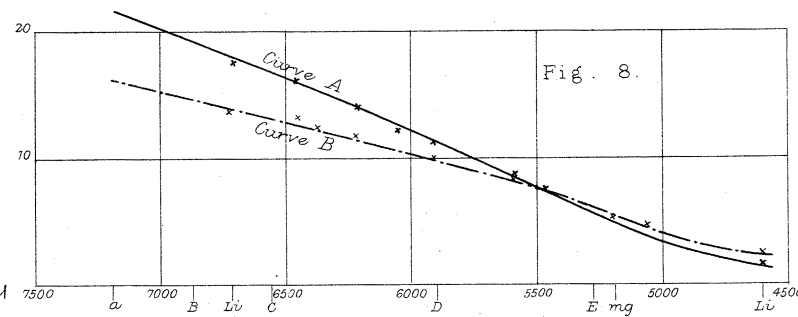
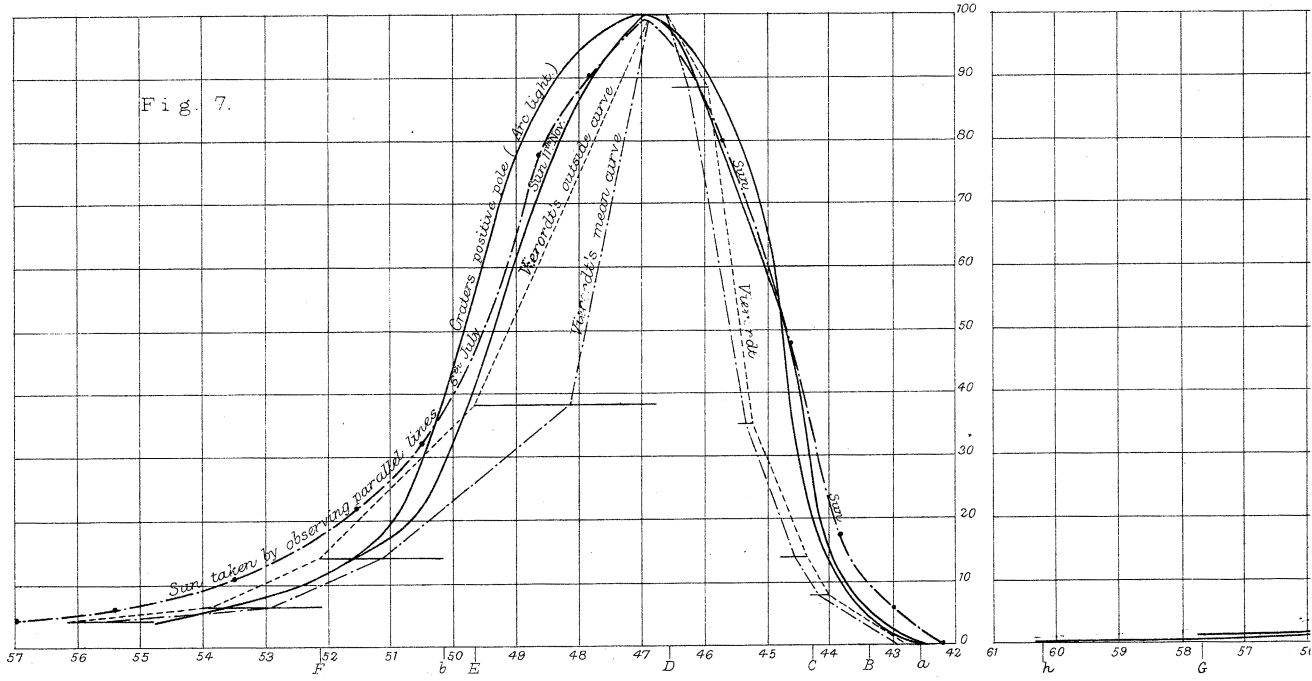

In Curve A the ordinates to be di  
 In Curve B the ordinates to be di

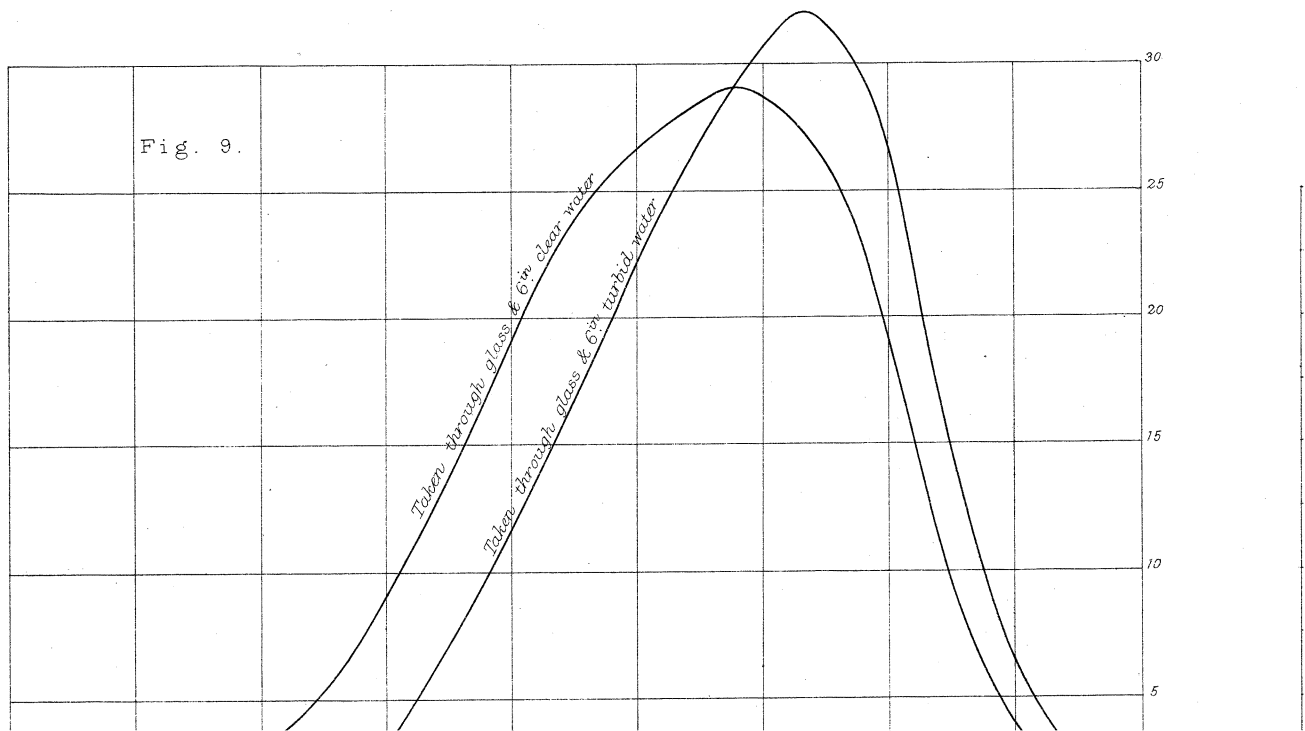

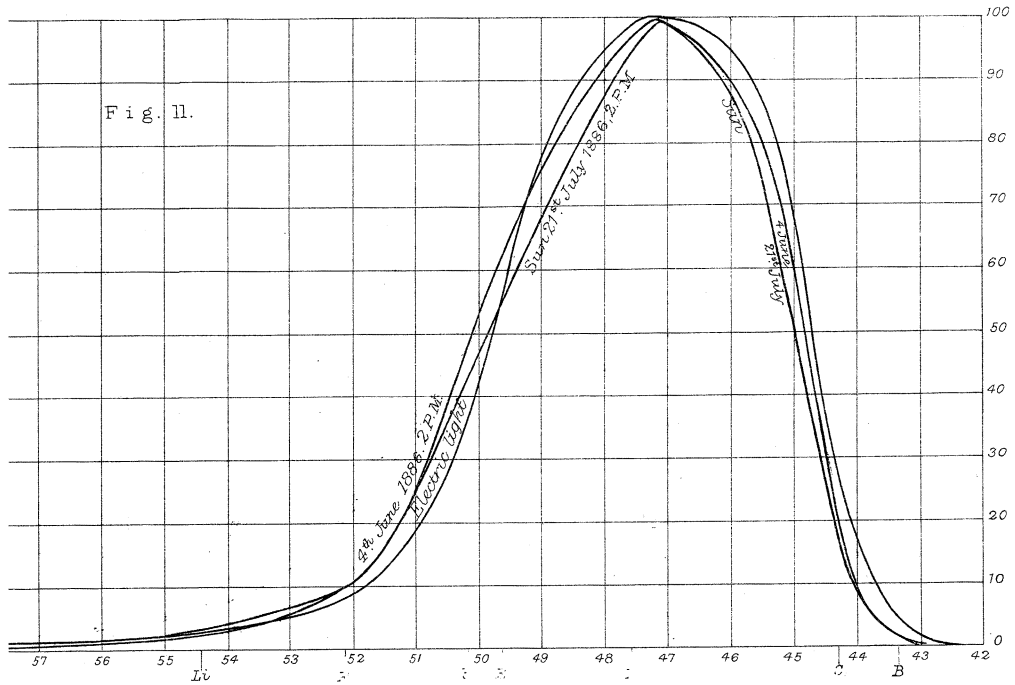

to be divided by 37.6 to bring to absolute measure

to be divided by 22.55 to bring to absolute measure.

Fig. 10.

Curve A is Incandescence lamp 102 Watts.

Curve B is Incandescence lamp 143 Watts.

Curve C is Incandescence lamp 266 Watts.

Curve D gas flame.

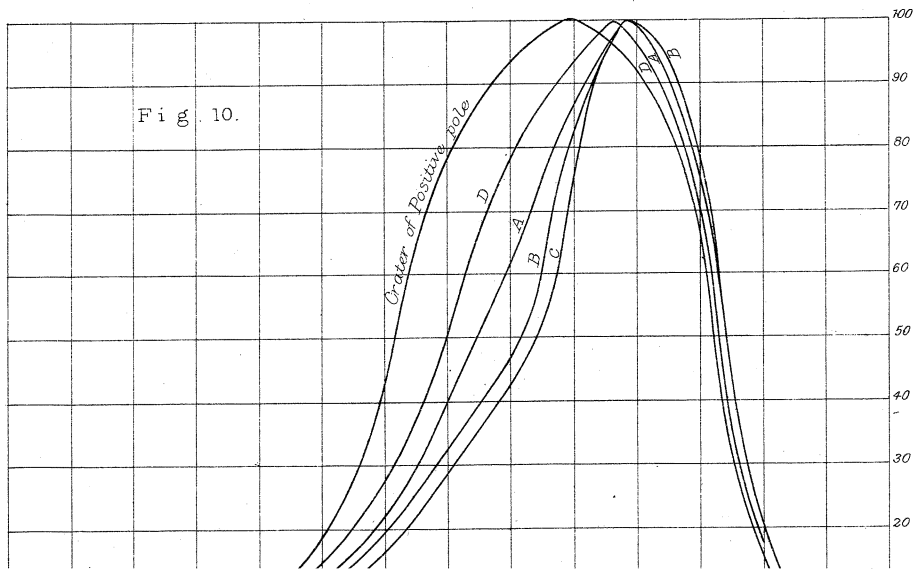



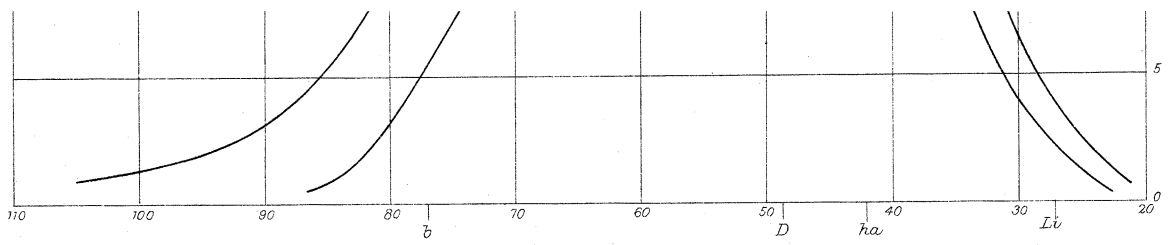

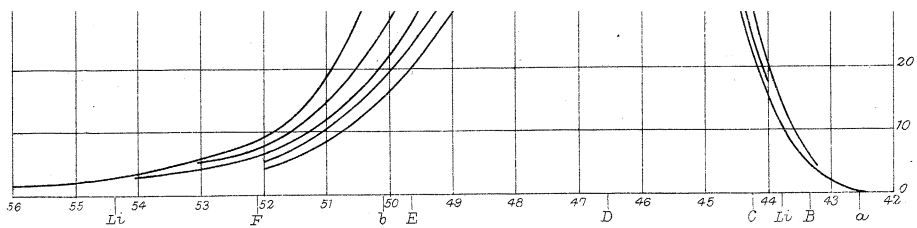

West, Newman & Co. lith.

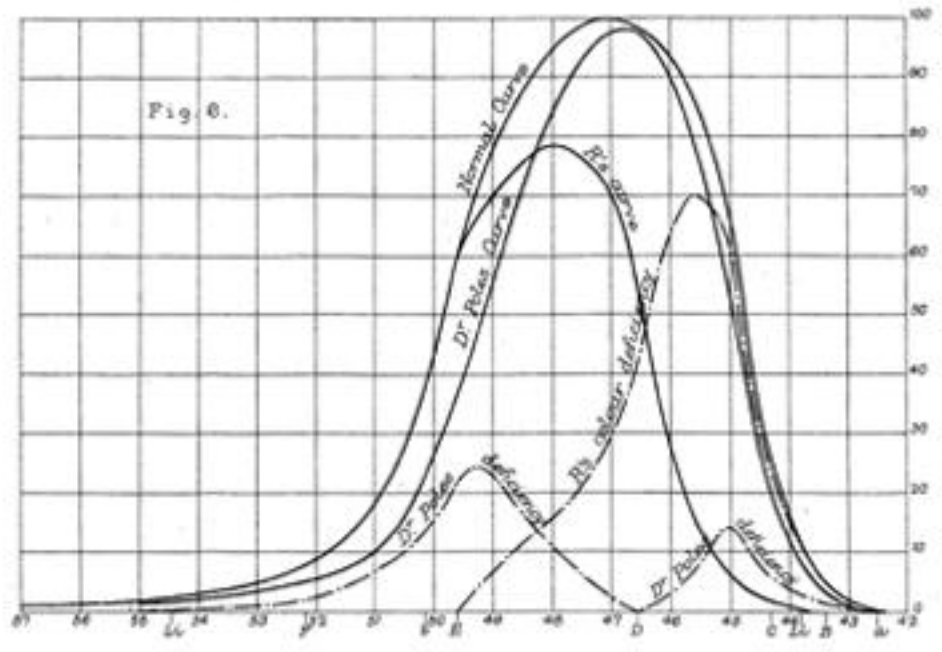
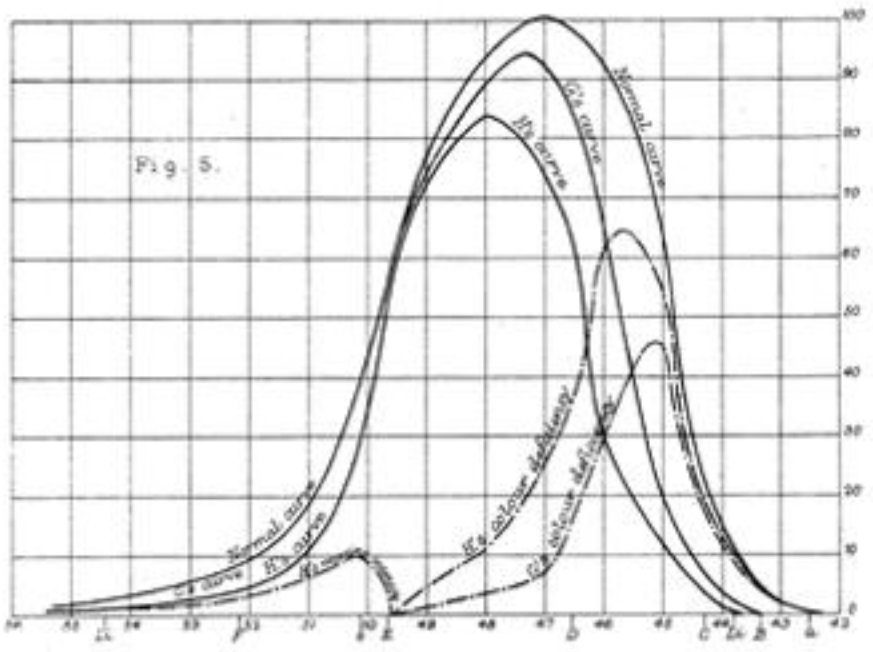
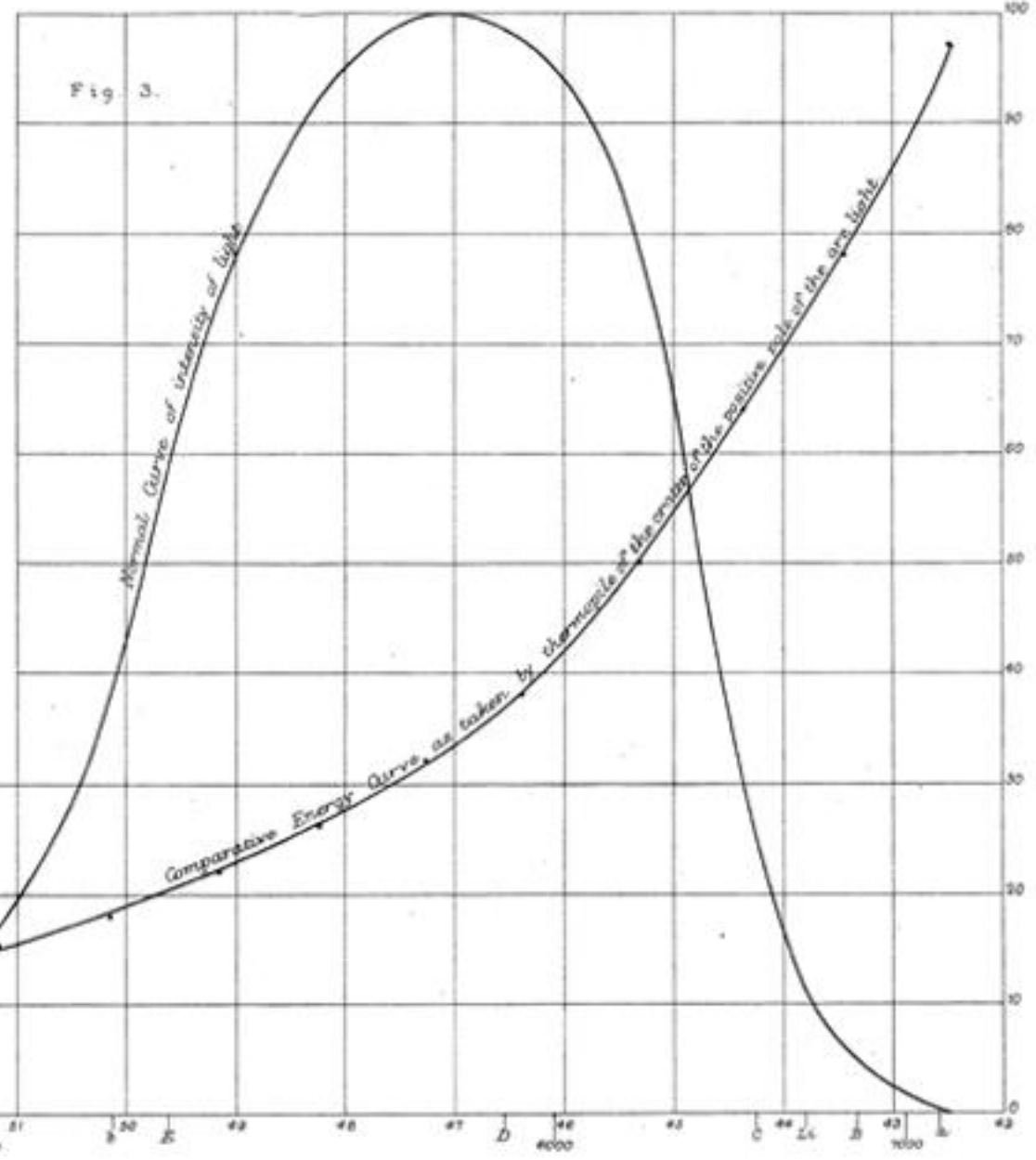
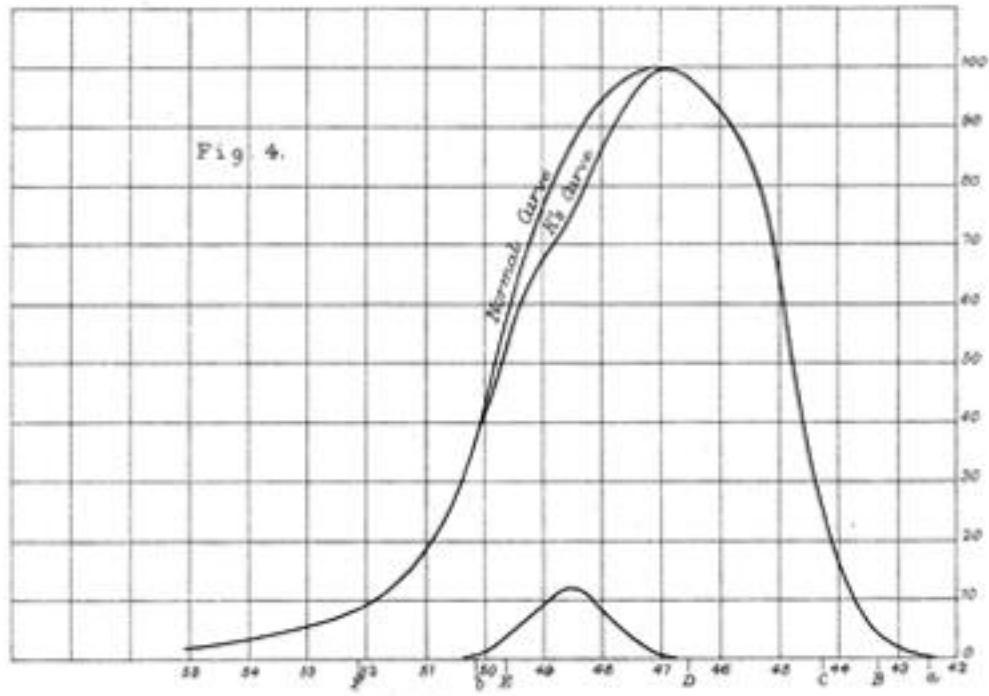

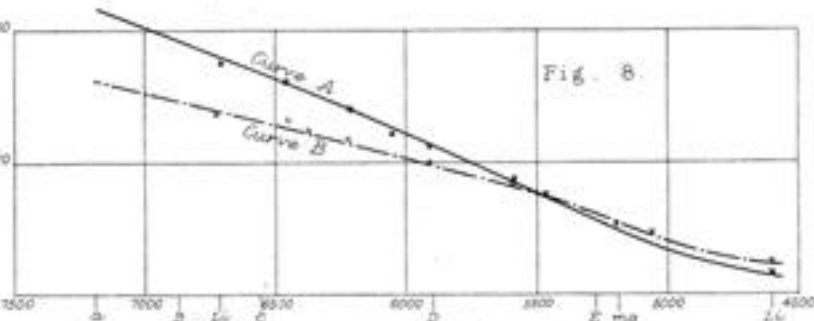
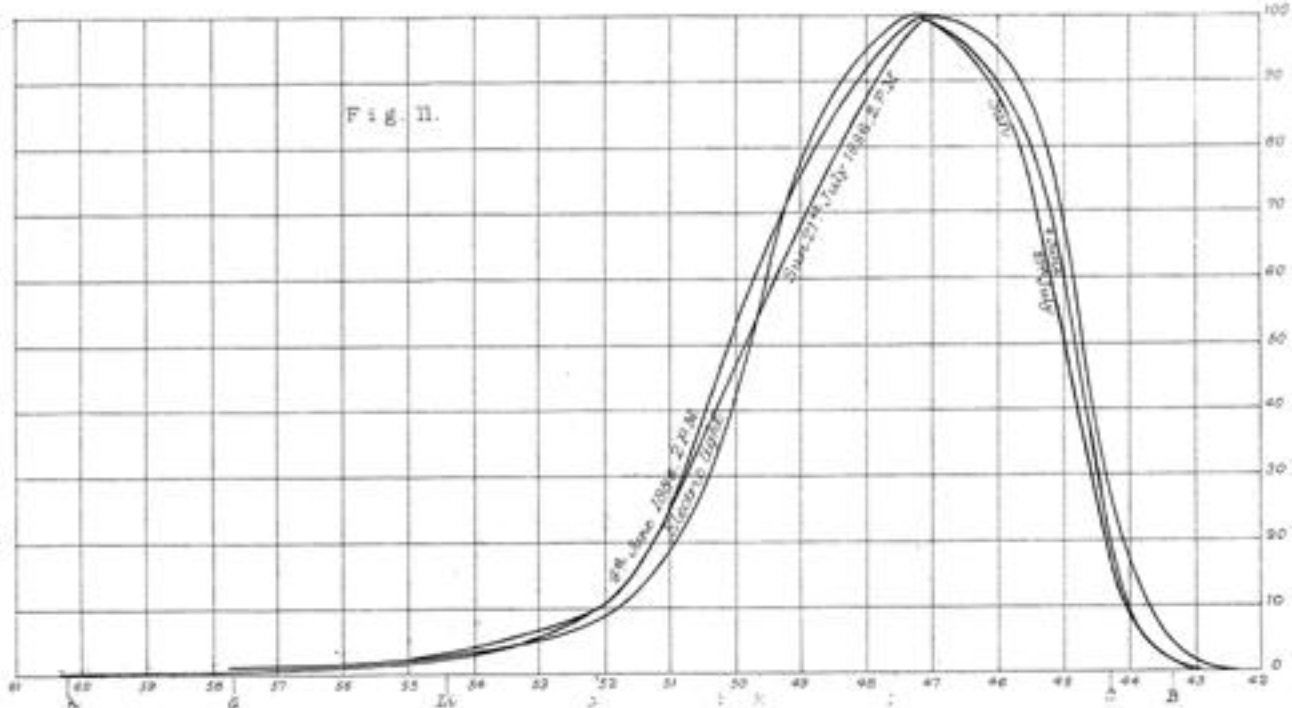
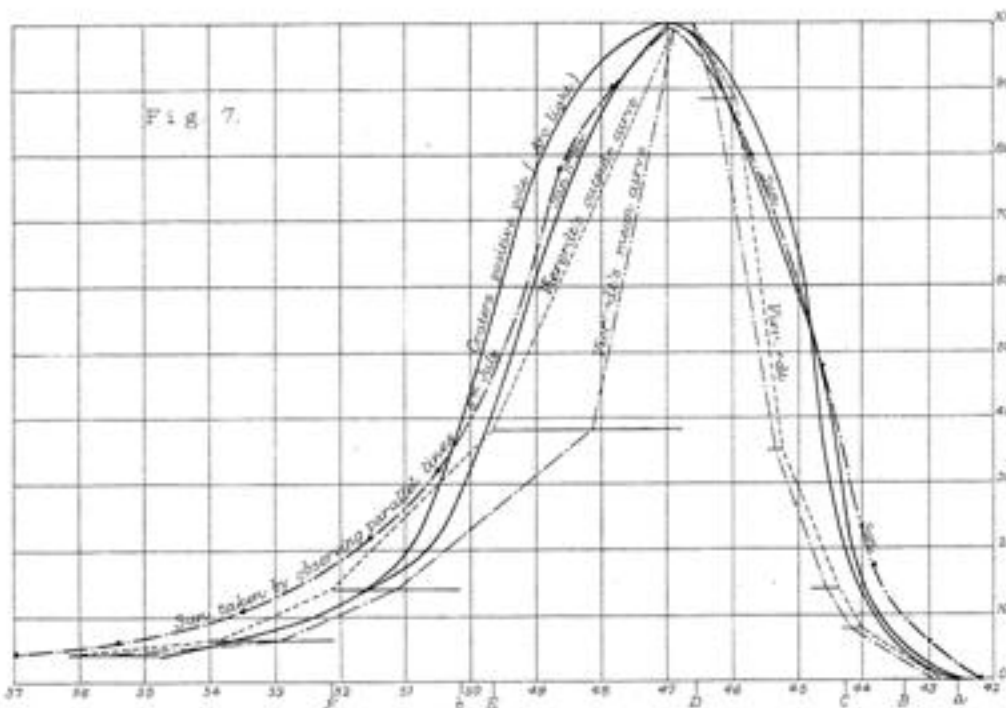

In Curve A the ordinates to be divided by 37.6 to bring to absolute measure  
 In Curve B the ordinates to be divided by 22.56 to bring to absolute measure.

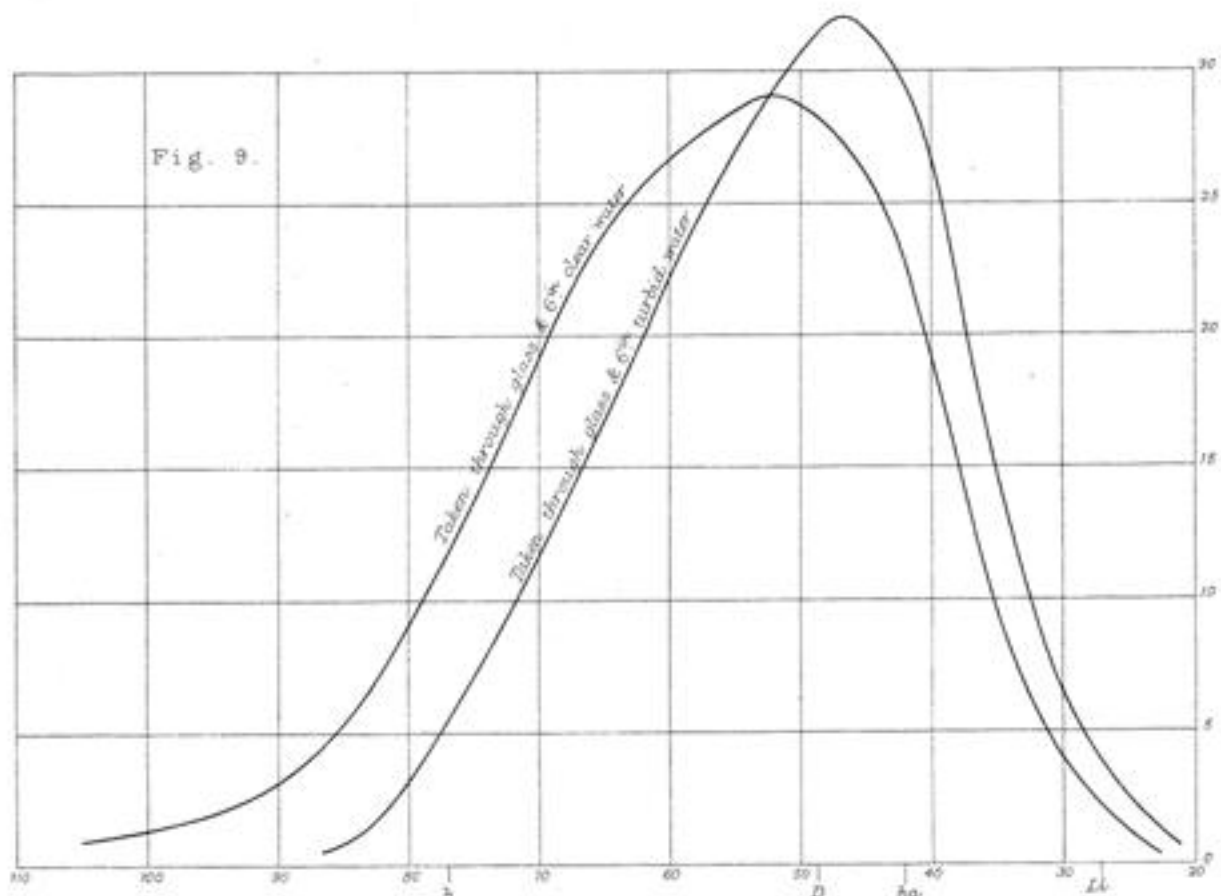

Fig. 10.  
 Curve A is Incandescence lamp 102 Watts.  
 Curve B is Incandescence lamp 143 Watts.  
 Curve C is Incandescence lamp 266 Watts.  
 Curve D gas flame.

